

PAPER NAME

**1044-2727-4-PB_Artikel_Muliadi_IJAI.R.p
df**

AUTHOR

Mulyadi Mulyadi

WORD COUNT

3955 Words

CHARACTER COUNT

21365 Characters

PAGE COUNT

12 Pages

FILE SIZE

675.5KB

SUBMISSION DATE

Jun 20, 2024 4:51 PM GMT+8

REPORT DATE

Jun 20, 2024 4:51 PM GMT+8

● 5% Overall Similarity

The combined total of all matches, including overlapping sources, for each database.

- 1% Internet database
- 1% Publications database
- Crossref database
- Crossref Posted Content database
- 5% Submitted Works database

● Excluded from Similarity Report

- Bibliographic material
- Quoted material
- Cited material
- Small Matches (Less than 10 words)
- Manually excluded sources
- Manually excluded text blocks

Automatic Water Level Controlling And Monitoring System Using Iot Application

Muliadi ^{a,1,*}, Isminarti ^{b,2}

^a Universitas Negeri Makassar, Jl. A. P. Pettarani, Makassar and 90222, Indonesia

^b Politeknik Bosowa, Jalan Kapasa Raya No. 23, Makassar and 90245, Indonesia

¹ muliadi7404@unm.ac.id*; ² isminarti@politeknikbosowa.ac.id

* muliadi7404@unm.ac.id

ARTICLE INFO

Article history

Received 29 Jul 2023

Revised 08 Sep 2023

Accepted 12 Des 2023

Keywords

Water level sensor

IoT

Smartphones

Firebase web server

ABSTRACT

Water tanks have recently been widely used in many applications in households or industry. It is essential to control the water level of a tank to regulate the filling process so that the tank does not overflow or empty without being noticed. This study aims to design an automatic water level control system using an IoT application to monitor and control processes. The sensor used in this study is a water level sensor, which detects the height of the water level. It works by the principle that the more water hitting the sensor, the smaller the resistance. The sensor can see whether the reservoir has reached a certain level or is complete. The sensor will inform the Wmos R1 board ESP8266 module to turn off the water pump engine and activate it again when the water level sensor reaches a certain level. The results show that the sensor worked correctly and accurately. When the water level sensor shows a whole height level in the filling process, which is 80% filled with water, the water level sensor will inform the Wmos R1 board ESP8266 module to change the relay to the OFF condition so that the water pump engine is also OFF. Upon detecting a specific height, when 50% of the tank has been filled with water, the pump engine restarts. The real-time ON/OFF status of the water pump monitoring the water using Telegram on a smartphone.

1. Introduction

Water has a vital role in the survival of living things on earth. Indonesia and even the world utilize water in daily life proportionally, both in the household environment and on an industrial scale. Humans use water for various household needs, for example, drinking water, bathing, washing, etc.

Advances in science and technology encourage humans to make equipment that can be used for various aspects of life, for example, controlling the water level in water reservoirs [1]. Other researchers use float and level switch systems to manage water in pools or tendons. The float system is usually in the form of a float ball, a float ball that will regulate the opening and closing of the water according to the water level in the water reservoir. This buoy system is mechanical, the working principle of which is this tool will open the water flow for filling. If the water level reaches the height of the float ball, the water flow is closed mechanically so that the water tap can open and close automatically. The weakness of this system is that it easily leaks from the faucet because it must also be able to withstand the water pressure in the pipe coming out of the water pump machine.

Meanwhile, the level switch system uses electrical relay contacts. It is almost the same as the buoy system, except that the buoy ball uses two weights attached to hang on one rope. Next, the regulating system uses relay contacts, and an electrical cable connects it to the water pump mechanism. When the water level in the reservoir is low, the water machine will start and then stop when the level is high according to the position setting of the two ballasts. The regulating system then uses relay contacts, and they are wired electrically to the water pumping apparatus. There are also several weaknesses in the level switch system, namely that the water pump machine will be

active more than once a day because the water in the water reservoir has not yet reached half of the water pump machine being active again and so on, resulting in wasteful use of electrical energy. Apart from that, there is no sign that the water reservoir is full [2].

A group of researchers produced a tank control system that utilizes a microcontroller as the control unit and a water level sensor made of metal so that this system can only control the water level in two conditions, namely low water level conditions for the motor on and high needs for the motorbike off [3].

Other research uses an automatic water level control system where the results of the study produce an automated water level control system that utilizes an infrared sensor which will give orders to the microcontroller to activate the water pump if the sensor reading is at the minimum level and will stop the pump if the sensor reading is at the maximum level. This research does not explicitly discuss water level monitoring [4].

Another research regarding Logical Automatic Water Control Systems for Domestic Applications uses logic gates as indicators for turning on and off water pumps where the control system controls the height of the water tank, so real-time control is challenging to implement [5]-[10].

Other researchers also discussed the use of IoT in water level monitoring, which makes it easier for users to monitor water levels [11]-[14].

Based on the description above, developing an automatic water level control system with monitoring using an IoT application in real-time is necessary. This system will regulate the filling of the water tank so that the tank does not overflow or empty without being noticed.

2. Method

This research aims to design an automatic water level control system by monitoring using an IoT application. The system design stages consist of hardware design and software design. Subsequently, the system underwent testing on a prototype shelter that had a reduced height of 27 cm. Figure 1 shows the prototype water reservoir model.



Fig. 1. Water reservoir prototype model

The hardware design consists of designing the power supply and installing the HC-SR04 ultrasonic sensor, water level sensor, and relay on the Wemos D1 R1 and ESP8266 modules.

Power supply design with 12V and +5V output. This power supply is a voltage source for the Wemos D1 R1 module and ESP8266 module and a voltage source for the water pump motor. The circuit image is as in Fig. 2.

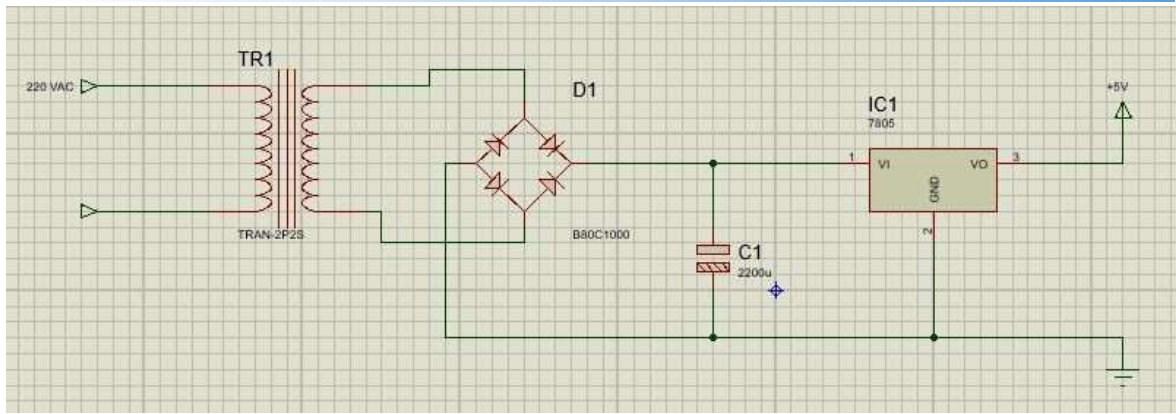

Fig. 2. The power supply circuit outputs 12V and +5V

4 An ultrasonic sensor consisting of 4 pins, namely VCC, Trig, Echo, and GND, was installed on the Wemos D1 ESP8266 board module. VCC and GND are connected to a voltage of +5 Volts, and the Ground power supply, Trig, and Echo of the HC-SR04 ultrasonic sensor are connected to pins D10 and D11 on the Wemos D1 module on the ESP8266 board as in Fig. 3.

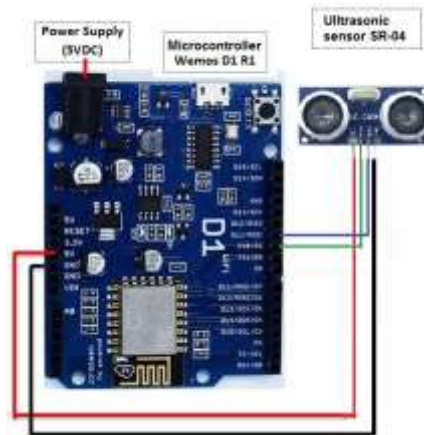

Fig. 3. Installation of the HC-SR04 ultrasonic sensor

Installation of the HW-038 water level sensor, namely a water sensor consisting of (+), (-), and S on the Wemos D1 board ESP8266 module. Pins (+) and (-) are connected to the +5V power supply and GND; pin S is connected to pin A0 of the Wemos D1 module on the ESP8266 board, as in Fig. 4.

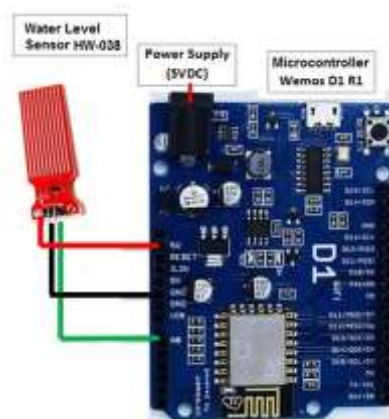

Fig. 4. Installation of the HW-038 water level sensor

The software design consists of several stages: creating a flowchart for an automatic water level control system, a monitoring program using the Telegram application for communication between the Wemos R1 board ESP8266, and a computer or smartphone device using an internet network.

Flowchart of the automatic water level control system with monitoring using the IoT application as in Fig. 5.

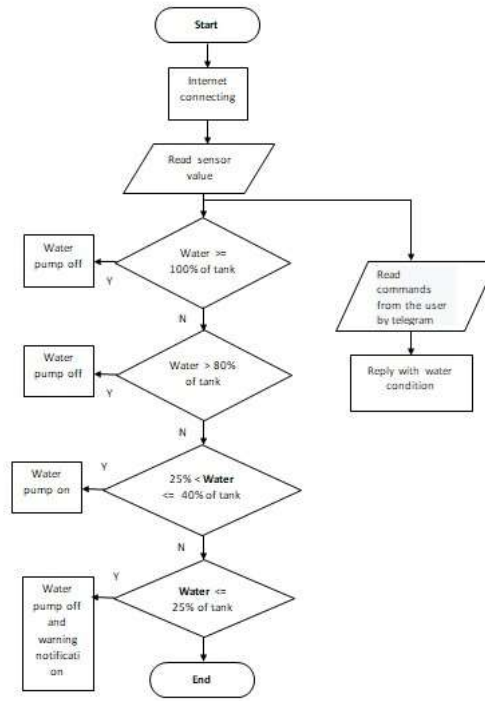

Fig. 5.Flowchart of an automatic water level control system with monitoring using an IoT application

The ultrasonic sensor reading program, water sensor reading program, and Telegram application program for communication between the Wemos D1 ESP8266 board and a computer or smartphone using the internet system are:

```

//include CTBot library
#include "CTBot.h";

//variables for telegram bot
CTBot myBot;

//configure wifi connection
String ssid = "Muliandira";
String pass = "R4h4s14@";

//Telegram token and ID variables
String token = "1399437790:AAHcGkG2iUQRRv2f-0sxIzNuWwQOJDkDnzI";
const int id = 1167350447;

//initialize wemos pin
#define ECHOPIN D11
#define TRIGPIN D10
#define relay D8

//variable ultrasonic sensors and water sensors
    
```

```

int waterSensor = A0;
int sensor value = 0;
int distance = 0;
int distance1 = 0;
int tank = 30; //Distance of tank bottom to the ultrasonic sensor
int water ;
int percentage;

void setup() {
  Serial.begin(9600);
  Serial.println("Starting Telegram. Wifi Connection");

  //connect to wifi
  myBot.wifiConnect(ssid,pass);
  //set telegram token
  myBot.setTelegramToken(token);

  //check wifi connection
  if(myBot.testConnection())
  Serial.println("Connection Successful");
  else
  Serial.println("Connection Failed");

  //mewos pin coding for ultrasonics and relays
  pinMode(ECHOPIN, INPUT);
  pinMode(TRIGPIN, OUTPUT);
  pinMode(relay, OUTPUT); //Relay is active LOW
}

void loop() {

  //processing of ultrasonic sensors and water sensors
  digitalWrite(TRIGPIN, LOW); delayMicroseconds(2);
  digitalWrite(TRIGPIN, HIGH); delayMicroseconds(10);
  digitalWrite(TRIGPIN, LOW);
  distance = pulseIn(ECHOPIN, HIGH);
  distance1= distance/58;
  water = tanks - distance1;
  percentage = map(water,0.27,0.100); // map(water, from_low (0cm), to_high(cm = tank - distance
  from ultrasonic sensor to spill water indicator sensor), to_low (0%), to_high(100%)
  Serial.print("Water level :"); Serial.print(water); Serial.println("cm");
  Serial.print("Percentage of water in reservoir: "); Serial.print(percentage); Serial.println("%");

  sensorValue = analogRead(waterSensor);
  Serial.println(percentage);

  TBMessage msg;

  if (sensorValue >= 100){
  digitalWrite(relay,HIGH );
  myBot.sendMessage(id, "Warning, the water volume exceeds the full limit. Check the system
  immediately");}

  else if (percentage >= 100){

```

```
digitalWrite(relay,HIGH );
myBot.sendMessage(id, "Warning, the water volume exceeds the full limit. Check the system
immediately");}

5 else if (percentage > 80){
digitalWrite(relay, HIGH);
Serial.println("Machine Off");}

else if ( percentage <= 40 ){
digitalWrite(relay, LOW);
Serial.println("Engine On");}

else if (percentage <= 25){
digitalWrite(relay, LOW);
Serial.println("Check System");
myBot.sendMessage(id, "Warning, the water volume is less than 25%. Check the system
immediately");}

if (myBot.getNewMessage(msg)) {
//variable for message
Message string = msg.text;
if(message == "/start")
{myBot.sendMessage(id, "Welcome to the automatic water level control system using the IOT
application monitoring. Reply with the word /check for information on water conditions");}
else if (message == "/check")
{myBot.sendMessage(id, (String)"The current water condition is " + percentage + (String)"%. " +
(String)"Thank You");}}
}
//include CTBot library
#include "CTBot.h";

//variables for telegram bot
CTBot myBot;

//configure wifi connection
String ssid = "Muliandira";
String pass = "R4h4s14@";

//Telegram token and id variables
String token = "1399437790:AAHcgkG2iUQRRv2f-0sxIzNuWwQOJDkDnzI";
const int id = 1167350447;

//initialize wemos pin
#define ECHOPIN D11
#define TRIGPIN D10
#define relay D8

//variable ultrasonic sensors and water sensors
int waterSensor = A0;
int sensorValue = 0;
int distance = 0;
int distance1 = 0;
int tank = 30; //Distance of tank bottom to ultrasonic sensor
int water ;
int percentage;
```



```
void setup() {
  Serial.begin(9600);
  Serial.println("Starting Telegram. Wifi Connection");

  //connect to wifi
  myBot.wifiConnect(ssid,pass);
  //set telegram token
  myBot.setTelegramToken(token);

  //check wifi connection
  if(myBot.testConnection())
  Serial.println("Connection Successful");
  else
  Serial.println("Connection Failed");

  //mewos pin coding for ultrasonics and relays
  pinMode(ECHOPIN, INPUT);
  pinMode(TRIGPIN, OUTPUT);
  pinMode(relay, OUTPUT); //Relay is active LOW
}

void loop() {

  //processing of ultrasonic sensors and water sensors
  digitalWrite(TRIGPIN, LOW); delayMicroseconds(2);
  digitalWrite(TRIGPIN, HIGH); delayMicroseconds(10);
  digitalWrite(TRIGPIN, LOW);
  distance = pulseIn(ECHOPIN, HIGH);
  distance1= distance/58;
  water = tanks - distance1;
  percentage = map(water,0.27,0.100); // map(water, from_low (0cm), to_high(cm = tank - distance
  from ultrasonic sensor to spill water indicator sensor), to_low (0%), to_high(100%)
  Serial.print("Water level :"); Serial.print(water); Serial.println("cm");
  Serial.print("Percentage of water in reservoir: "); Serial.print(percentage); Serial.println("%");

  sensorValue = analogRead(waterSensor);
  Serial.println(percentage);

  TBMessage msg;

  if (sensorValue >= 100){
  digitalWrite(relay,HIGH );
  myBot.sendMessage(id, "Warning, the water volume exceeds the full limit. Check the system
  immediately");}

  else if (percentage >= 100){
  digitalWrite(relay,HIGH );
  myBot.sendMessage(id, "Warning, the water volume exceeds the full limit. Check the system
  immediately");}

  else if (percentage > 80){
  digitalWrite(relay, HIGH);
  Serial.println("Machine Off");}
```



```
else if ( percentage <= 40 ){
digitalWrite(relay, LOW);
Serial.println("Engine On");}

else if(percentage <= 25){
digitalWrite(relay, LOW);
Serial.println("Check System");
myBot.sendMessage(id, "Warning, the water volume is less than 25%. Check the system
immediately");}

if (myBot.getNewMessage(msg)) {
//variable for message
Message string = msg.text;
if(message == "/start")
{myBot.sendMessage(id, "Welcome to the automatic water level control system using the IOT
application monitoring. Reply with the word /check for information on water conditions");}
else if (message == "/check")
{myBot.sendMessage(id, (String)"The current water condition is " + percentage + (String)"%. " +
(String)"Thank You");}}
}
```

Testing monitoring system using the Telegram application, the first step is to activate Telegram and search for the project name, namely Automatic_air_level_control_system Once successful, send a /start message so that there is a real welcome to IOT Based Automatic Water Pumping and Monitoring System. Reply with the word/check for information on water conditions. Send another message, namely /check so that there is a reply. The current water condition is 74%. Thank You. If the state of the water in the reservoir exceeds 80% volume so that the water overflows or spills, the water sensor will work and send a message, namely Warning, Water volume exceeds the full limit. Check the system immediately.

3. Results and Discussion

Results pThe ultrasonic sensor consists of 4 pins, namely VCC, Trig, Echo, and GND, on the Wemos D1 ESP8266 board module. VCC and GND are connected to +5 Volt voltage and Ground power supply, and Trig and Echo ultrasonic sensor HC-SR04 are connected to pins D10 and D11 on the Wemos D1 module on the ESP8266 board as in the picture. Installation of the HW-038 water level sensor, namely a water sensor consisting of (+), (-), and S on the Wemos D1 board ESP8266 module. Pins (+) and (-) are connected to the +5V power supply and GND; pin S is connected to pin A0 of the Wemos D1 module on the ESP8266 board, as in Fig. 6.



Fig. 6. Installation of the HC-SR04 ultrasonic sensor and water level sensor on the Wemos D1 board ESP8266 module

The results of installing a water level control system using the IoT application in a water reservoir are shown in Fig. 7.



Fig. 7.Installation of a water level control system using an IoT application in a water reservoir

The results of creating the project name, user name, and token in the Telegram application are shown in Fig. 8.

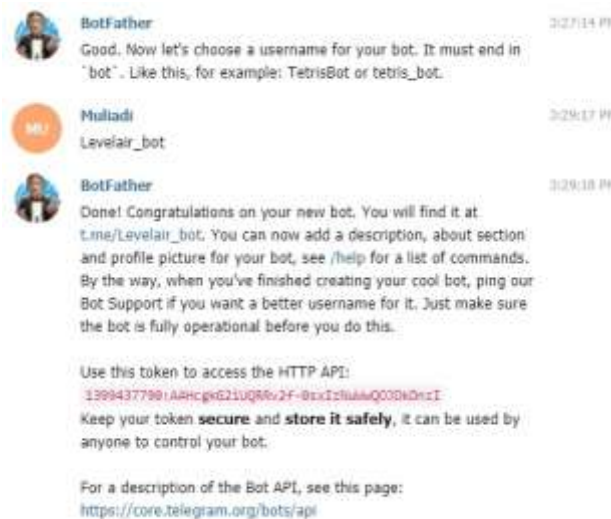

Fig. 8.Results of creating a project name, user name, and token in the Telegram application

Results of an automatic water level control system using IoT application monitoring when filling water reservoirs. The water reservoir used is 27 cm high with a water pump machine with a voltage of 12VDC, as shown in Table 1.

Table 1. Results of an automatic water level control system using IoT application monitoring when filling water reservoirs.

No	Water volume (%)	Water pump machine condition	Water level (cm)
1	10	ON	2.7
2	20	ON	5.5
3	30	ON	8.2
4	40	ON	10.8
5	50	ON	13.5
6	60	ON	16.3
7	70	ON	18.9
8	80	OFF	22

Results of an automatic water level control system using IoT application monitoring while reducing reservoir water. The water reservoir used is 27 cm high with a water pump machine with a voltage of 12VDC, shown in Table 2.

Table 2. Results of an automatic water level control system using iot application monitoring in the storage water reduction process

No	Water volume (%)	Water pump machine condition (ON/OFF)	Water level (cm)
1	80	OFF	22
2	70	OFF	18.9
3	60	OFF	16.3
4	50	OFF	13.5
5	40	ON	12.5

The results of monitoring using the Telegram application during the process of filling the water reservoir with a water volume of 74% are shown in Fig. 9.



Fig. 9.Monitoring results of the reservoir water filling process at 74% volume

The research results show that the prototype automatic water level control system using IoT monitoring was successfully designed and accessed via computer or smartphone using the Telegram application.

Based on the results of the automatic water level control system using IoT application monitoring when filling the water reservoir. The water reservoir used is 27 cm high with a water pump machine with a voltage of 12VDC. Table 1 shows that in the water filling process, the system starts working when the reservoir is empty, and the water pump machine remains active or ON when the water volume reaches 10% of the reservoir water volume until the water volume is less than 80% or the height is less than 22 cm. When the water volume reaches 80% or a height of 22 cm, the water pump machine is inactive or OFF. The difference between the theoretical water level and the test results is around 0.4 cm.

Based on the results of the automatic water level control system using IoT application monitoring when reducing storage water. The water reservoir used is 27 cm high with a water pump machine with a voltage of 12VDC. Table 2 shows that in the process of reducing water in the reservoir, the system starts not working when the pool has a water volume of 80% or a height of 22 cm. This condition lasts until the water volume is reduced at a magnitude greater than 40% or a height greater than 12.5 cm. When the water volume is exactly 40%, and the height is 12.5, the water pump machine is active or ON again, and the filling process continues. This observation was carried out several times. The difference between the theoretical water level and the test results is around 1.7 minus the filling error of 0.4 cm to 1.3 cm.

Based on the results of monitoring the water conditions in the reservoir using the Telegram application, results were obtained in Figure 9, which shows that in testing the monitoring system using the Telegram application, the steps are to activate Telegram and search for the project name, namely Automatic air level control system Once successful, send a /start message so that there is a real welcome to IOT Based Automatic Water Pumping and Monitoring System. Reply with the word/check for information on water conditions. Send another message, namely /check so that there is a reply. The current water condition is 74%. Thank You. If the condition of the water in the reservoir exceeds 80% volume so that the water overflows or spills, the water sensor will work and send a message, namely Warning: Water volume exceeds the full limit. Check the system immediately.

4. Conclusion

An automatic water level control system with monitoring using the Telegram application in prototype form has been successfully created and functions as automatic water level control and can be monitored for water conditions via the Telegram application in the form of warning messages or on request.

Automatic water level control by the system can be done by activating the water pump machine until the water volume reaches 80 percent volume or a water height of 22 cm during the filling process and the water pump machine is deactivated. The water pump machine is activated again when the water volume is at 40 percent volume or a height of 12.5 cm.

Monitoring using Telegram can take the form of checking the condition of the water volume and in the form of a warning when the water volume exceeds a specified limit or the water volume overflows or spills.

References

- [1] MLCD Lml, "EEICT Journal <https://ojs.uniska-bjm.ac.id/index.php/eeict>," vol. 1, pp. 41–52.
- [2] E. Dewanto, J. Yoseph, F. Teknik, and UN Jakarta, "Automatic Water Tank with Monitoring System via Android Based on Arduino Uno," pp. 8–16.
- [3] S. Das, S. Dhar, PB Deb, and PS Majumdar, "Microcontroller Based Water Level Indicator and Controller," vol. 1, no. 5, pp. 181–182, 2017.
- [4] A. Ahmed, M. Eltaieb, and ZJ Min, "Automatic Water Level Control System," vol. 4, no. 12, pp. 1505–1509, 2015.
- [5] H. Jamal, "Logical Automatic Water Control System For Domestic Applications," no. December, 2016.
- [6] F. Bruno, M. De Marchis, B. Milici, D. Saccone, and F. Traina, "A pressure monitoring system for water distribution networks based on arduino microcontroller," *Water*, 2021, [Online]. Available: <https://www.mdpi.com/2073-4441/13/17/2321>
- [7] A. Djalilov, N. Juraeva, O. Nazarov, "Intellectual system for water flow and water level control in water management," 2020.
- [8] M. F. M. Zin, F. Z. Kamal, S. I. Ismail, K. Noh, "Development of dam controller technology water level and alert system using Arduino UNO," *Engineering and academia.edu*, 2023. [Online]. Available: https://www.academia.edu/download/105550023/32220_66413_1_PB.pdf
- [9] A. A. Ismail, M. A. Azizi, and A. Zariman, "Smart Water Level Indicator," *Int. J. Recent*, 2020, [Online]. Available: <https://lamintang.org/journal/index.php/ijortas/article/view/59>
- [10] O. O. Akinwale, "Design, simulation and implementation of an Arduino microcontroller based automatic water level controller with I2C LCD display," *Journal of Advances in Applied Sciences ... pdfs.semanticscholar.org*, 2020. [Online]. Available: <https://pdfs.semanticscholar.org/b348/8461e7ea2dbbb2be75d779dcb84e6bb82705.pdf>
- [11] S. Choubey, P. William, A. B. Pawar, "Intelligent water level monitoring and water pump controlling system using IOT," *Electron*, 2022, [Online]. Available: <https://ieeexplore.ieee.org/abstract/document/9885358/>
- [12] P. Sreekaran, V. Rakesh, P. Vaishnavi, P. Sujala, "Novel Design Analysis of Water Level Indicator using IoT Technologies," *Journal of Science jscer.org*, 2022. [Online]. Available: <https://jscer.org/IoT Security Technologies.pdf>
- [13] K. Chaduvula, B. R. Markapudi, and C. R. Jyothi, "Design and Implementation of IoT based flood alert monitoring system using microcontroller 8051," *Mater. Today Proc.*, 2023, [Online]. Available: <https://www.sciencedirect.com/science/article/pii/S2214785321049002>

-
- [14] F. Jan, N. Min-Allah, S. Saeed, S. Z. Iqbal, and R. Ahmed, "IoT-based solutions to monitor water level, leakage, and motor control for smart water tanks," *Water*. mdpi.com, 2022. [Online]. Available: <https://www.mdpi.com/2073-4441/14/3/309>

● **5% Overall Similarity**

Top sources found in the following databases:

- 1% Internet database
- 1% Publications database
- Crossref database
- Crossref Posted Content database
- 5% Submitted Works database

TOP SOURCES

The sources with the highest number of matches within the submission. Overlapping sources will not be displayed.

1	arduino.stackexchange.com Internet	1%
2	Universitas Negeri Jakarta on 2023-08-14 Submitted works	<1%
3	De Montfort University on 2023-10-15 Submitted works	<1%
4	University of Birmingham on 2024-03-28 Submitted works	<1%
5	Emirates Aviation College, Aerospace & Academic Studies on 2016-1... Submitted works	<1%
6	Universitas Semarang on 2024-01-25 Submitted works	<1%
7	Universiti Teknologi MARA on 2017-07-15 Submitted works	<1%
8	Universiti Teknologi MARA on 2019-01-13 Submitted works	<1%

● Excluded from Similarity Report

- Bibliographic material
- Cited material
- Manually excluded sources
- Quoted material
- Small Matches (Less than 10 words)
- Manually excluded text blocks

EXCLUDED SOURCES

ijair.id Internet	84%
eprints.unm.ac.id Internet	16%
mail.ijair.id Internet	11%
ijair.id Internet	11%
insightsociety.org Internet	6%
journal.umy.ac.id Internet	4%

EXCLUDED TEXT BLOCKS

International Journal of Artificial Intelligence Research Vol. 7, No. 2, December 2023

Farhan Fathur Ramadhan, Andri Sahata Sitanggang, Julian Chandra Wibawa, Nizar Rabbi Radliya. "Impleme..."

ISSN 2579-7298

UIN Syarif Hidayatullah Jakarta on 2023-04-17