

## PAPER NAME

**1.B.1.5. Journal of Applied Mathematics  
\_Hindawi 15-1-21\_1-8-2021.pdf**

---

## WORD COUNT

**5053 Words**

## CHARACTER COUNT

**22656 Characters**

## PAGE COUNT

**8 Pages**

## FILE SIZE

**694.5KB**

## SUBMISSION DATE

**Jun 20, 2023 10:01 AM GMT+8**

## REPORT DATE

**Jun 20, 2023 10:01 AM GMT+8**

---

● **20% Overall Similarity**

The combined total of all matches, including overlapping sources, for each database.

- 13% Internet database
- 11% Publications database
- Crossref database
- Crossref Posted Content database
- 13% Submitted Works database

● **Excluded from Similarity Report**

- Bibliographic material
- Manually excluded sources
- Manually excluded text blocks

## Research Article

# Analysis and Simulation of SIRS Model for Dengue Fever Transmission in South Sulawesi, Indonesia

Wahidah Sanusi,<sup>1</sup> Nasiah Badwi,<sup>2</sup> Ahmad Zaki,<sup>1</sup> Sahlan Sidjara,<sup>1</sup> Nurwahidah Sari,<sup>1</sup> Muhammad Isbar Pratama,<sup>1</sup> and Syafruddin Side<sup>1</sup> 

<sup>1</sup>Mathematics Department, Universitas Negeri Makassar, Makassar 90222, Indonesia

<sup>2</sup>Geography Department, Universitas Negeri Makassar, Makassar 90222, Indonesia

Correspondence should be addressed to Syafruddin Side; [syafruddin@unm.ac.id](mailto:syafruddin@unm.ac.id)

Received 1 August 2020; Revised 11 December 2020; Accepted 31 December 2020; Published 15 January 2021

Academic Editor: Yansheng Liu

Copyright © 2021 Wahidah Sanusi et al. This is an open access article distributed under the Creative Commons Attribution License, which permits unrestricted use, distribution, and reproduction in any medium, provided the original work is properly cited.

This study is aimed at building and analysing a SIRS model and also simulating the model to predict the number of dengue fever cases. Methods applied for this model are building the SIRS model by modifying the SIR model, analysing the SIRS model using the Lyapunov function to prove three theorems (the existence, the free disease, and the endemic status of dengue fever), and simulating the SIRS model using the number of dengue case data in South Sulawesi by Maple. The results obtained are the SIRS model of dengue fever transmission, stability analysis, global stability, and the value of the basic reproduction number  $R_0$ . The simulation done for the dengue fever case in South Sulawesi found the basic reproduction number  $R_0 = 26.47609 > 1$ ; it means that South Sulawesi is in the endemic stage of transmission for dengue fever disease. Simulation of the SIRS model for dengue fever can predict the number of dengue cases in South Sulawesi that could be a recommendation for the government in an effort to prevent the number of dengue fever cases.

## 1. Introduction

The World Health Organization [1] revealed the rapid increase in the number of dengue fever (DF) cases that reached 30 times during the last 50 years. Considered the most transmitting disease in the world, the DF virus may potentially infect more than half of the world population. Annual data reports [1] show that the number of patients suffering from the DF in hospitals is in the interval of a half to a million people.

Dengue fever (DF) is a type of disease in tropical regions, especially Indonesia, including South Sulawesi [1]. Based on data from the Ministry of Health of the Republic of Indonesia (2013), the number of dengue cases in South Sulawesi has increased from year to year as shown in Figure 1. The following is the updated DF victims as of 20 January 2016 for several districts/cities in South Sulawesi province: 32 city cases of Makassar, 645 cases of Bone district, 11 cases of Gowa district, 56 cases of Maros district, 125 cases of Pangkep dis-

trict, 23 cases of Sinjai district, and 225 cases of Luwu district, while other districts/cities have not been recorded [1].

Studies investigating appropriate mathematical models for the dengue fever cases were done using the model of Suspected, Infected, and Removed (SIR) and Suspected, Exposed, Infected, and Removed (SEIR) [2–21]. The SIR models assumed that individuals who recovered from the disease would no longer be infected. Recent facts, however, show possibilities of a recovered patient to be suspected for the second time. This becomes the main reason to modify the SIR into SIRS [19]. This paper is the extension of the SIRS model [19] with analysis, and the simulation presented in this article is a reliable alternative reference to control the happening of DF in a region. The former part of the article discusses formulation of the SIRS model for the DF transmission, the second part contains analysis of the model involving three theorems and investigation of the model stability, and the last part presents simulations of the SIRS model performed for both free disease and endemic cases.

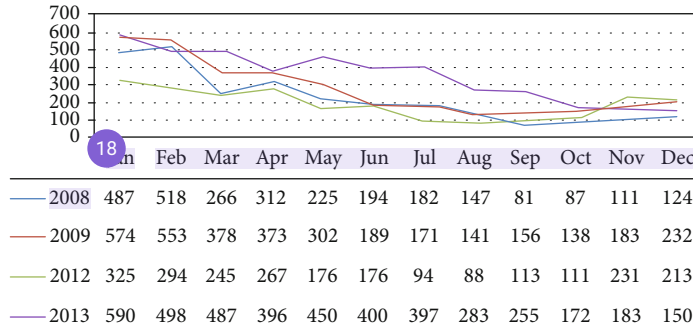

FIGURE 1: Trends in dengue fever cases in South Sulawesi.

## 2. Materials and Methods

This is a theoretical study on the model of dengue fever transmission. The SIRS model is developed by modifying the SIR model [8, 9] that has been previously used. The model is then analysed to prove the existence theorem, the free disease, and the endemic cases of DF using the method of Lyapunov function [10, 11]. Afterwards, global stability of the SIRS is investigated using the Eigenvalue equation [9]. The simulation of the model used the number of dengue case data in South Sulawesi by Maple. The simulation is done to describe and predict the number of dengue fever cases in South Sulawesi.

## 3. Results

**3.1. SIRS Model of Dengue Fever Disease Transmission.** There are several assumptions used in model formation: the total population of humans and mosquitoes is considered constant, the rate of birth and mortality rate are considered equal, births in mosquitoes and human populations in each class enter into the suspected class, each individual in the population is likely to have the same mosquito bites, the infected mosquito bite rate is higher than the suspected mosquito, and each recovered individual has the possibility of reinfection so that it reenters the suspected class. The parameters used in the dengue fever disease model are presented in Table 1.

Changes that occur in the human and the mosquito classes can be interpreted in Figure 2.

Figure 2 can be interpreted in the form of a mathematical model that is a host-vector interaction model which is the following nonlinear differential equation:

$$\begin{aligned}
 \frac{dS_h}{dt} &= \mu_h N_h - \frac{\beta_h b}{N_h} I_v S_h - \mu_h S_h + \theta_h R_h, \\
 \frac{dI_h}{dt} &= \frac{\beta_h b}{N_h} I_v S_h - (\mu_h + \gamma_h) I_h, \\
 \frac{dR_h}{dt} &= \gamma_h I_h - (\mu_h + \theta_h) R_h, \\
 \frac{dS_v}{dt} &= \mu_v N_v - \frac{\beta_v b}{N_h} I_h S_v - \mu_v S_v, \\
 \frac{dI_v}{dt} &= \frac{\beta_v b}{N_h} I_h S_v - \mu_v I_v,
 \end{aligned}
 \tag{1}$$

with conditions  $S_h + I_h + R_h \leq N_h$  and  $N_v = A/\mu_v$ .

TABLE 1: Definition of variable/parameter.

| Variable/parameter | Definition                                         |
|--------------------|----------------------------------------------------|
| $N_h$              | Number of human population                         |
| $N_v$              | Number of mosquito population                      |
| $\mu_h$            | Birth and mortality of human population            |
| $\mu_v$            | Birth and mortality of mosquito population         |
| $b$                | The rate of mosquito bites                         |
| $\gamma_h$         | The rate of cure for disease                       |
| $\theta_h$         | The rate of decline in human immunity to disease   |
| $\beta_v$          | Probability of spreading virus from $I_h$ to $S_v$ |
| $\beta_h$          | Probability of spreading virus from $I_v$ to $S_h$ |
| $\beta_v b$        | Interaction capabilities $I_h$ and $S_v$           |
| $\beta_h b$        | Interaction capabilities $I_v$ and $S_h$           |
| $A$                | The rate of mosquito recruitment                   |

## 4. Analysis of SIRS Model for Dengue Fever Transmission

All variables and parameters in the model are nonnegatives as observable in the equation system (1), and the nonnegative octant  $R_+^5$  is positive invariant. Based on the equation system (1), we derive Theorem 1, we shall prove the positivity of solution for the SIRS model.

**Theorem 1.** Let  $(S_h(t) > 0, I_h(t) > 0, R_h(t) > 0, S_v(t) > 0, I_v(t) > 0)$  be the solution of the equation system (1) with initial condition  $(S_{0h}, I_{0h}, R_{0h}, S_{0v}, I_{0v})$  on the compact set

$$D = \left\{ (S_h(t), I_h(t), R_h(t), S_v(t), I_v(t)) \in R_+^5, L_1 \right. \\
 \left. = \{ S_h + I_h + R_h \leq N_h, L_2 = S_v + I_v \leq N_v = \frac{A}{\mu_v} \} \right\}.
 \tag{2}$$

For the model system (1), the region  $D$  is a positive invariant that contains any solutions of  $R_+^5$ .

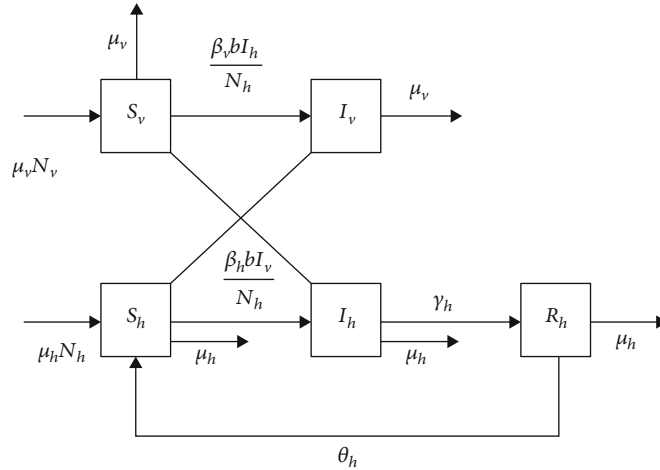

FIGURE 2: SIRS model diagram of human and vector population [19].

2. *roof.* A Lyapunov function constructed for the system is

$$L(t) = (L_1(t), L_2(t)) = (S_h + I_h + R_h, S_v + I_v). \quad (3)$$

2. The derivative of  $L(t)$  with respect to time that satisfies equation (3) is

$$\begin{aligned} \frac{dL}{dt} &= \left( \frac{dL_1}{dt}, \frac{dL_2}{dt} \right) = \left( \frac{dS_h}{dt} + \frac{dI_h}{dt} + \frac{dR_h}{dt}, \frac{dS_v}{dt} + \frac{dI_v}{dt} \right) \\ &= \mu_h N_h - \frac{\beta_h b I_h}{N_h} S_h - \mu_h S_h + \theta_h R_h + \frac{\beta_h b}{N_h} I_v S_h \\ &\quad - (\mu_h + \gamma_h) I_h + \gamma_h I_h - (\mu_h + \theta_h) R_h, \mu_v N_v \\ &\quad - \frac{\beta_v b}{N_h} I_h S_v - \mu_v S_v + \frac{\beta_v b}{N_h} I_v S_v - \mu_v I_v \\ &= (\mu_h N_h - \mu_h (S_h + I_h + R_h), A - \mu_v (S_v + I_v)) \\ &= (\mu_h N_h - \mu_h L_1, A - \mu_v L_2). \end{aligned} \quad (4)$$

Thus, we can find

$$\begin{cases} \frac{dL_1}{dt} = \mu_h N_h - \mu_h L_1 \leq 0, \text{ for } L_1 \geq N_h, \\ \frac{dL_2}{dt} = A - \mu_v L_2 \leq 0, \text{ for } L_2 \geq \frac{A}{\mu_v}. \end{cases} \quad (5)$$

Hence, by equation (5), we obtained that  $dL/dt \leq 0$  which implies that  $D$  is a positive invariant set. Meanwhile, solving equation system (5) results in

$$0 \leq (L_1(t), L_2(t)) \leq \left( N_h + L_1(0)e^{-\mu_h t}, \frac{A}{\mu_v} + L_2(0)e^{-\mu_v t} \right), \quad (6)$$

where  $L_1(0)$  and  $L_2(0)$  are the initial condition of  $L_1(t)$  and  $L_2(t)$  consecutively.

Hence, as  $t \rightarrow \infty, 0 \leq (L_1(t), L_2(t)) \leq (N_h, A/\mu_h)$ . This confirms that  $D$  is a positive invariant set containing all the solutions in  $R_+^5$ . This proves Theorem 1.

Theorem 1 guarantees the existence of DF transmission in a region in which the DF transmitting virus was formerly absent and then changed when the population of suspected but not infected,  $S_h(t) > 0$ , infected,  $I_h(t) > 0$ , and recovered individual,  $R_h(t) > 0$ , from DF was found. The theorem also indicates an advance study on the stages of the DF transmission by which a region can be identified as free disease or endemic with the use of the SIRS model.

### 5. Global Stability Analysis

System (1) for the SIRS model of the DF transmission applies the equilibrium value of  $(S_h^*, I_h^*, R_h^*, S_v^*, I_v^*) = (N_h, 0, 0, A/\mu_v, 0)$ . The Jacobian matrix of equation system (1) is defined as follows:

$$J = \begin{bmatrix} -\frac{\beta_h b I_v}{N_h} - \mu_h & 0 & \theta_h & 0 & -\frac{\beta_h b S_h}{N_h} \\ \frac{\beta_h b I_v}{N_h} & -\mu_h - \gamma_h & 0 & 0 & \frac{\beta_h b S_h}{N_h} \\ 0 & \gamma_h & -\mu_h - \theta_h & 0 & 0 \\ 0 & -\frac{\beta_v b S_v}{N_h} & 0 & -\frac{\beta_v b I_h}{N_h} - \mu_v & 0 \\ 0 & \frac{\beta_v b S_v}{N_h} & 0 & \frac{\beta_v b I_h}{N_h} & -\mu_v \end{bmatrix}. \quad (7)$$

By considering the equilibrium point, we obtain

$$J = \begin{bmatrix} -\mu_h & 0 & \theta_h & 0 & -\beta_h b \\ 0 & -\mu_h - \gamma_h & 0 & 0 & \beta_h b \\ 0 & \gamma_h & -\mu_h - \theta_h & 0 & 0 \\ 0 & -\frac{\beta_v b S_v}{N_h} & 0 & -\mu_v & 0 \\ 0 & \frac{\beta_v b S_v}{N_h} & 0 & 0 & -\mu_v \end{bmatrix}. \quad (8)$$

In order to find the Eigenvalue  $\lambda$ , we simplify system (1) and then solve the equation  $|J - \lambda I|$ , that is,

$$\begin{vmatrix} -\mu_h - \lambda & 0 & \theta_h & 0 & -\beta_h b \\ 0 & -\mu_h - \gamma_h - \lambda & 0 & 0 & \beta_h b \\ 0 & \gamma_h & -\mu_h - \theta_h - \lambda & 0 & 0 \\ 0 & -\frac{\beta_v b S_v}{N_h} & 0 & -\mu_v - \lambda & 0 \\ 0 & \frac{\beta_v b S_v}{N_h} & 0 & 0 & -\mu_v - \lambda \end{vmatrix} = 0,$$

$$(-\mu_h - \lambda) \begin{vmatrix} -\mu_h - \gamma_h - \lambda & 0 & 0 & \beta_h b \\ \gamma_h & -\mu_h - \theta_h - \lambda & 0 & 0 \\ -\frac{\beta_v b S_v}{N_h} & 0 & -\mu_v - \lambda & 0 \\ \frac{\beta_v b S_v}{N_h} & 0 & 0 & -\mu_v - \lambda \end{vmatrix} = 0,$$

$$(-\mu_h - \lambda)(-\mu_v - \lambda)(-\mu_h - \theta_h - \lambda) \cdot ((-\mu_h - \gamma_h - \lambda)(-\mu_v - \lambda) - (\beta_h b)\beta_v b) = 0. \tag{9}$$

The Eigenvalues obtained are

$$\begin{aligned} \lambda_1 &= -\mu_h, \\ \lambda_2 &= -\mu_v, \\ \lambda_3 &= -\mu_h - \theta_h, \end{aligned} \tag{10}$$

and the Eigenvalue equation is

$$\lambda^2 + (\mu_h + \mu_v + \gamma_h)\lambda + (\mu_h + \gamma_h)\mu_v - b\beta_h b\beta_v = 0. \tag{11}$$

From equation (11), the basic reproduction number  $R_0$  for system (1) of the SIRS model can be obtained using the method [20, 21], that is,

$$R_0 = \frac{b\beta_h b\beta_v}{\mu_v(\mu_h + \gamma_h)}. \tag{12}$$

### 6. Global Stability of Free Disease Equilibrium of Model SIRS

Equation system (1) applies free disease equilibrium of  $(S_h^*, I_h^*, R_h^*, S_v^*, I_v^*) = (N_h, 0, 0, A/\mu_v, 0)$  indicating the possibility of the disease to fade out. Theorem 2 explains the behavior of the free disease equilibrium globally for equation (1).

**Theorem 2.** If  $R_0 \leq 1$ , then the free disease equilibrium  $(S_h^*, I_h^*, R_h^*, S_v^*, I_v^*) = (N_h, 0, 0, A/\mu_v, 0)$  in the global stage is asymptotically stable in  $D$ , by assuming that

$$\mu_h = \frac{\beta_v b}{N_h} S_v^*, \tag{13}$$

$$\mu_v = \frac{\beta_h b}{N_h} S_h^*.$$

**2**roof. A Lyapunov function constructed for the system is

$$W(t) = (S_h - S_h^* \ln S_h) + I_h + R_h + (S_v - S_v^* \ln S_v) + I_v. \tag{14}$$

The derivative of  $W(t)$  with respect to time that satisfies equation (14) is

$$\begin{aligned} \dot{W}(t) &= \dot{S}_h \left(1 - \frac{S_h^*}{S_h}\right) + \dot{I}_h + \dot{R}_h + \dot{S}_v \left(1 - \frac{S_v^*}{S_v}\right) + \dot{I}_v \\ &= \left(\mu_h N_h - \frac{\beta_h b I_v}{N_h} S_h - \mu_h S_h + \theta_h R_h\right) \left(1 - \frac{S_h^*}{S_h}\right) \\ &\quad + \frac{\beta_h b I_v}{N_h} S_h - \mu_h I_h - \gamma_h I_h + \gamma_h I_h - \mu_h R_h - \theta_h R_h \\ &\quad + \left(A - \frac{\beta_v b I_h}{N_h} S_v - \mu_v S_v\right) \left(1 - \frac{S_v^*}{S_v}\right) + \frac{\beta_v b I_h}{N_h} S_v - \mu_v I_v \\ &= \mu_h N_h \left(1 - \frac{S_h^*}{S_h}\right) + \mu_h S_h^* \left(1 - \frac{S_h}{S_h^*}\right) - \frac{\beta_h b I_v}{N_h} S_h \\ &\quad + \frac{\beta_h b I_v}{N_h} S_h \left(\frac{S_h^*}{S_h}\right) - \theta_h R_h \left(\frac{S_h^*}{S_h}\right) + \frac{\beta_h b I_v}{N_h} S_h - \mu_h I_h \\ &\quad - \mu_h R_h + A \left(1 - \frac{S_v^*}{S_v}\right) + \mu_v S_v^* \left(1 - \frac{S_v}{S_v^*}\right) - \frac{\beta_v b I_h}{N_h} S_v \\ &\quad + \frac{\beta_v b I_h}{N_h} S_v \left(\frac{S_v^*}{S_v}\right) + \frac{\beta_v b I_h}{N_h} S_v - \mu_v I_v \\ &= \mu_h N_h \left(1 - \frac{S_h^*}{S_h}\right) + \mu_h S_h^* \left(1 - \frac{S_h}{S_h^*}\right) + \frac{\beta_h b I_v}{N_h} S_h^* \\ &\quad - \theta_h R_h \left(\frac{S_h^*}{S_h}\right) - \mu_h I_h - \mu_h R_h + A \left(1 - \frac{S_v^*}{S_v}\right) \\ &\quad + \mu_v S_v^* \left(1 - \frac{S_v}{S_v^*}\right) + \frac{\beta_v b I_h}{N_h} S_v^* - \mu_v I_v \\ &= \mu_h N_h \left(1 - \frac{S_h^*}{S_h}\right) + \mu_h S_h^* \left(1 - \frac{S_h}{S_h^*}\right) - \theta_h R_h \left(\frac{S_h^*}{S_h}\right) \\ &\quad - \mu_h R_h + A \left(1 - \frac{S_v^*}{S_v}\right) + \mu_v S_v^* \left(1 - \frac{S_v}{S_v^*}\right) \\ &\quad + \left(\frac{\beta_v b}{N_h} S_v^* - \mu_h\right) I_h + \left(\frac{\beta_h b}{N_h} S_h^* - \mu_v\right) I_v. \end{aligned} \tag{15}$$

Considering  $S_h^* = N_h, S_v^* = A/\mu_v$ , condition (13) to equation (15) can be expressed as

$$\begin{aligned} \dot{W}(t) &= \mu_h N_h \left(1 - \frac{S_h^*}{S_h} + 1 - \frac{S_h}{S_h^*}\right) - \theta_h R_h \left(\frac{S_h^*}{S_h}\right) - \mu_h R_h \\ &\quad + A \left(1 - \frac{S_v^*}{S_v} + 1 - \frac{S_v}{S_v^*}\right) = \mu_h N_h \left(2 - \frac{S_h^*}{S_h} - \frac{S_h}{S_h^*}\right) \\ &\quad - \theta_h R_h \left(\frac{S_h^*}{S_h}\right) - \mu_h R_h + A \left(2 - \frac{S_v^*}{S_v} - \frac{S_v}{S_v^*}\right) \\ &= -\mu_h N_h \frac{(S_h - S_h^*)^2}{S_h S_h^*} - \theta_h R_h \left(\frac{S_h^*}{S_h}\right) - A \frac{(S_v - S_v^*)^2}{S_v S_v^*} - \mu_h R_h. \end{aligned} \tag{16}$$

Equation (16) shows that  $\dot{W}(t) \leq 0$ . Using the Lyapunov method [10], the finite sets applicable for the solution are those contained in the largest invariant set, where  $S_h = S_h^*$ ,  $R_h = 0$ , and  $S_v = S_v^*$ , that is, the singleton set  $\{S_h^*, R_h^*, S_v^*, I_v^*\}$ . This implies if the free disease equilibrium  $S_h^*, I_h^*, R_h^*, S_v^*, I_v^*$  is the global stage asymptotically stable in  $D$ . This proves Theorem 2.

This global stability theorem for the free disease case of the SIRS model explains a stage of the existence of the DF case, as explained in Theorem 1. Theorem 2 says that if  $R_0 \leq 1$ , then an infected individual will not infect others. Thus, DF in this stage can still be controlled and should not be worried about.

### 7. Global Stability of Endemic Equilibrium of Model SIRS

The SIRS model of system (1) as an equilibrium point of  $P^{**} = (S_h^{**}, I_h^{**}, R_h^{**}, S_v^{**}, I_v^{**}) \in D$  called the endemic equilibrium point, which satisfies  $S_h^{**} > 0, I_h^{**} > 0, R_h^{**} > 0, S_v^{**} > 0, I_v^{**} > 0$ , where

$$\begin{aligned}
 S_h^{**} &= \frac{N_h^2 \mu_v (\mu_h + \gamma_h) (\beta_v \mu_h b + \beta_v b \theta_h + \mu_h \mu_v + \mu_v \gamma_h + \mu_v \theta_h)}{(\beta_h \mu_h A b + \beta_h A b \gamma_h + \beta_h A b \theta_h + \mu_h^2 \mu_v N_h + \mu_h \mu_v N_h \gamma_h + \mu_h \mu_v N_h \theta_h + \mu_v N_h \gamma_h \theta_h) \beta_v b}, \\
 I_h^{**} &= \frac{(\mu_h + \theta_h) N_h (\beta_h \beta_v A b^2 - \mu_h \mu_v^2 N_h - \mu_v^2 N_h \gamma_h)}{(\beta_h \mu_h A b + \beta_h A b \gamma_h + \beta_h A b \theta_h + \mu_h^2 \mu_v N_h + \mu_h \mu_v N_h \gamma_h + \mu_h \mu_v N_h \theta_h + \mu_v N_h \gamma_h \theta_h) \beta_v b}, \\
 R_h^{**} &= \frac{N_h \gamma_h (\beta_h \beta_v A b^2 - \mu_h \mu_v^2 N_h - \mu_v^2 N_h \gamma_h)}{(\mu_h A b + \beta_h A b \gamma_h + \beta_h A b \theta_h + \mu_h^2 \mu_v N_h + \mu_h \mu_v N_h \gamma_h + \mu_h \mu_v N_h \theta_h + \mu_v N_h \gamma_h \theta_h) \beta_v b}, \\
 S_v^{**} &= \frac{\beta_h \mu_h A b + \beta_h A b \gamma_h + \beta_h A b \theta_h + \mu_h^2 \mu_v N_h + \mu_h \mu_v N_h \gamma_h + \mu_h \mu_v N_h \theta_h + \mu_v N_h \gamma_h \theta_h}{(\beta_v \mu_h b + \beta_v b \theta_h + \mu_h \mu_v + \mu_v \gamma_h + \mu_v \theta_h) \beta_h b}, \\
 I_v^{**} &= \frac{(\mu_h + \theta_h) (\beta_h \beta_v A b^2 - \mu_h \mu_v^2 N_h - \mu_v^2 N_h \gamma_h)}{\mu_v (\beta_v \mu_h b + \beta_v b \theta_h + \mu_h \mu_v + \mu_v \gamma_h + \mu_v \theta_h) \beta_h b}.
 \end{aligned}
 \tag{17}$$

The following theorem explains the endemic global equilibrium of system (1).

**Theorem 3.**  $R_0 > 1$ , then the equilibrium status of DF diseases is positively endemic, and equation system (1) exists and is in the global stage asymptotically stable in  $D$  by assuming that

$$\begin{aligned}
 S_h^{**} &= N_h, \\
 S_v^{**} &= \frac{A}{\mu_v}, \\
 \mu_h &= \frac{\beta_v b (\mu_h + \gamma_h + \theta_h)}{N_h r}, \\
 \mu_v &= \frac{r \beta_h b}{(\mu_h + \gamma_h + \theta_h) S_v^{**}},
 \end{aligned}
 \tag{18}$$

where  $r = \beta_h b / N_h$  is the rate of mosquito population mortality,  $N_h$  is the number of the human population which is likely the same as the number of DF suspected,  $b$  is the rate

of potentially infecting mosquito bites, and  $\beta_h b$  is the interaction capability between humans and mosquitoes as the vector.

*Proof.* We constructed the Lyapunov function of the form in

$$\begin{aligned}
 V(t) &= (S_h - S_h^{**} \ln S_h) + I_h + R_h + \frac{\mu_h + \gamma_h + \theta_h}{r S_v^{**}} (S_v - S_v^{**} \ln S_v) \\
 &\quad + \frac{\mu_h + \gamma_h + \theta_h}{r S_v^{**}} I_v.
 \end{aligned}
 \tag{19}$$

The derivative of  $V(t)$  with respect to time that satisfies equation (19) is

$$\begin{aligned}
 \dot{V}(t) &= \dot{S}_h \left(1 - \frac{S_h^{**}}{S_h}\right) + \dot{I}_h + \dot{R}_h + \dot{S}_v \left(1 - \frac{S_v^{**}}{S_v}\right) \left(\frac{\mu_h + \gamma_h + \theta_h}{r S_v^{**}}\right) \\
 &\quad + \frac{\mu_h + \gamma_h + \theta_h}{r S_v^{**}} \dot{I}_v = \mu_h N_h \left(1 - \frac{S_h^{**}}{S_h}\right) + \theta_h R_h \left(1 - \frac{S_h^{**}}{S_h}\right) \\
 &\quad - \mu_h S_h \left(1 - \frac{S_h^{**}}{S_h}\right) - \frac{b \beta_h I_v}{N_h} \left(1 - \frac{S_h^{**}}{S_h}\right) + \frac{b \beta_h}{N_h} S_h \\
 &\quad - \mu_h I_h - \gamma_h I_h + \gamma_h I_h - \mu_h R_h - \theta_h R_h + \left(\frac{\mu_h + \gamma_h + \theta_h}{r S_v^{**}}\right) \\
 &\quad \cdot A \left(1 - \frac{S_v^{**}}{S_v}\right) - \left(\frac{\mu_h + \gamma_h + \theta_h}{r S_v^{**}}\right) \frac{b \beta_v I_h}{N_h} S_v \left(1 - \frac{S_v^{**}}{S_v}\right) \\
 &\quad - \left(\frac{\mu_h + \gamma_h + \theta_h}{r S_v^{**}}\right) \mu_v S_v \left(1 - \frac{S_v^{**}}{S_v}\right) + \left(\frac{\mu_h + \gamma_h + \theta_h}{r S_v^{**}}\right) \\
 &\quad \cdot \frac{b \beta_v I_h}{N_h} S_v - \left(\frac{\mu_h + \gamma_h + \theta_h}{r S_v^{**}}\right) \mu_v I_v = \mu_h N_h \left(1 - \frac{S_h^{**}}{S_h}\right) \\
 &\quad + \theta_h R_h - \theta_h R_h \left(\frac{S_h^{**}}{S_h}\right) - \mu_h S_h \left(1 - \frac{S_h^{**}}{S_h}\right) - \frac{b \beta_h I_v}{N_h} S_h \\
 &\quad + \frac{b \beta_h I_v}{N_h} S_h^{**} + \frac{b \beta_h I_v}{N_h} S_h - \mu_h I_h - \mu_h R_h - \theta_h R_h \\
 &\quad + A \left(\frac{\mu_h + \gamma_h + \theta_h}{r S_v^{**}}\right) - A \left(\frac{\mu_h + \gamma_h + \theta_h}{r S_v}\right) - \frac{b \beta_v I_h}{N_h} S_v \\
 &\quad \cdot \left(\frac{\mu_h + \gamma_h + \theta_h}{r S_v^{**}}\right) + \frac{b \beta_v I_h}{N_h} \left(\frac{\mu_h + \gamma_h + \theta_h}{r}\right) \\
 &\quad - \left(\frac{\mu_h + \gamma_h + \theta_h}{r}\right) \mu_v \left(\frac{S_v}{S_v^{**}}\right) + \mu_v \left(\frac{\mu_h + \gamma_h + \theta_h}{r}\right) \\
 &\quad + \left(\frac{\mu_h + \gamma_h + \theta_h}{r}\right) \frac{b \beta_h I_v}{N_h} \left(\frac{S_v}{S_v^{**}}\right) - \left(\frac{\mu_h + \gamma_h + \theta_h}{r S_v^{**}}\right) \mu_v I_v \\
 &= \mu_h N_h \left(1 - \frac{S_h^{**}}{S_h}\right) + \mu_h S_h^{**} \left(1 - \frac{S_h^{**}}{S_h}\right) - \theta_h R_h \left(\frac{S_h^{**}}{S_h}\right) - \mu_h R_h \\
 &\quad + \frac{b \beta_h I_v}{N_h} S_h^{**} - \mu_h I_h + A \left(\frac{\mu_h + \gamma_h + \theta_h}{r S_v^{**}}\right) - A \left(\frac{\mu_h + \gamma_h + \theta_h}{r S_v}\right) \\
 &\quad + \frac{b \beta_v I_h}{N_h} \left(\frac{\mu_h + \gamma_h + \theta_h}{r}\right) - \left(\frac{\mu_h + \gamma_h + \theta_h}{r}\right) \mu_v \left(\frac{S_v}{S_v^{**}}\right) \\
 &\quad + \mu_v \left(\frac{\mu_h + \gamma_h + \theta_h}{r}\right) - \left(\frac{\mu_h + \gamma_h + \theta_h}{r S_v^{**}}\right) \mu_v I_v.
 \end{aligned}
 \tag{20}$$

Substituting equation (18) into equation (20), we can find

$$\begin{aligned} \dot{V}(t) = & \mu_h N_h \left[ 2 - \frac{S_h^{**}}{S_h} - \frac{S_h}{S_h^{**}} \right] - \theta_h R_h \left( \frac{S_h^{**}}{S_h} \right) \\ & - \mu_h R_h + \left( \frac{b\beta_h}{N_h} S_h^{**} - \left( \frac{\mu_h + \gamma_h + \theta_h}{r S_v^{**}} \right) \mu_v \right) I_v \\ & + \left( \frac{b\beta_v}{N_h} \left( \frac{\mu_h + \gamma_h + \theta_h}{r} \right) - \mu_h \right) I_h + \left( \frac{\mu_h + \gamma_h + \theta_h}{r S_v^{**}} \right) \mu_v S_v^{**} \\ & - \left( \frac{\mu_h + \gamma_h + \theta_h}{r S_v} \right) \mu_v S_v^{**} + \mu_v \left( \frac{\mu_h + \gamma_h + \theta_h}{r} \right) \\ & - \left( \frac{\mu_h + \gamma_h + \theta_h}{r} \right) \mu_v \left( \frac{S_v}{S_v^{**}} \right), \end{aligned} \tag{21}$$

$$\begin{aligned} \mu_h N_h \left[ 2 - \frac{S_h^{**}}{S_h} - \frac{S_h}{S_h^{**}} \right] - \theta_h R_h \left( \frac{S_h^{**}}{S_h} \right) - \mu_h R_h + \frac{2\mu_v}{r} (\mu_h + \gamma_h + \theta_h) \\ - \left( \frac{\mu_h + \gamma_h + \theta_h}{r} \right) \mu_v \left( \frac{S_v}{S_v^{**}} \right) - \left( \frac{\mu_h + \gamma_h + \theta_h}{r} \right) \mu_v \left( \frac{S_v^{**}}{S_v} \right) \\ \cdot \mu_h N_h \left[ 2 - \frac{S_h^{**}}{S_h} - \frac{S_h}{S_h^{**}} \right] + \left( \frac{\mu_h + \gamma_h + \theta_h}{r} \right) \mu_v \left[ 2 - \frac{S_v^{**}}{S_v} - \frac{S_v}{S_v^{**}} \right] \\ - \theta_h R_h \left( \frac{S_h^{**}}{S_h} \right) - \mu_h R_h = -\mu_h N_h \left[ \frac{(S_h - S_h^{**})^2}{S_h S_h^{**}} \right] \\ - \mu_v \left[ \frac{\mu_h + \gamma_h + \theta_h}{r} \right] \left[ \frac{(S_v - S_v^{**})^2}{S_v S_v^{**}} \right] - \theta_h R_h \left( \frac{S_h^{**}}{S_h} \right) - \mu_h R_h. \end{aligned} \tag{22}$$

Equation (22) shows that  $\dot{V}(t) \leq 0$  for all  $S_h^{**}, I_h^*, R_h^{**}, S_v^{**}, I_v^{**} \in D, S_h^*, I_h^*, R_h^{**}, S_v^{**}, I_v^{**}$  and  $\dot{V}(t) = 0$  for  $S_h = S_h^{**}, I_h = I_h^*, R_h = R_h^{**}, S_v = S_v^{**}$ , and  $I_v = I_v^*$ . Equilibrium  $P^*$  is a set of positive invariant of system (1) that is contained in

$$\begin{aligned} L = \{ (S_h(t), I_h(t), R_h(t), S_v(t), I_v(t)), S_h = S_h^{**}, I_h = I_h^*, \\ R_h = R_h^{**}, S_v = S_v^{**}, I_v = I_v^* \}. \end{aligned} \tag{23}$$

Using the asymptotical stability theorem, positive endemic equilibrium  $P^*$  is in the global stage asymptotically stable in  $D$ . This proves Theorem 3.

The global stability theorem for the model SIRS in this stage tells if an individual is infected with DF with  $R_0 > 1$ ; then, the individual will likely infect at least another individual. Thus, the DF in this situation has been endemic, uncontrolled, and threatening for the human population within the region.

### 8. Simulation of SIRS Model for Dengue Fever Transmission in South Sulawesi, Indonesia

Simulation of the model is performed using the software Maple. Initial values  $S_h(0), I_h(0), R_h(0), S_v(0)$ , and  $I_v(0)$  used in the simulation are based on the data shown in Table 2, which are data related to dengue fever in South Sulawesi. Meanwhile, the basic reproduction number  $R_0$  is obtained from equation (12), that is,

TABLE 2: The initial and parameter values of the SIRS model simulation.

| Variable | Initial values | Source | Parameter  | Value ( $R_0 > 1$ ) | Source     |
|----------|----------------|--------|------------|---------------------|------------|
| $N_h(0)$ | 8771970        | [22]   | $b\beta_h$ | 0.750000            | [9]        |
| $S_h(0)$ | 8768197        | [22]   | $\mu_h$    | 0.000046            | [9]        |
| $I_h(0)$ | 1895           | [23]   | $\theta_h$ | 0.575000            | Assumption |
| $R_h(0)$ | 1878           | [23]   | $\gamma_h$ | 0.328833            | [9]        |
| $N_v(0)$ | 1000000        | [9]    | $\mu_v$    | 0.032300            | [9]        |
| $S_v(0)$ | 944000         | [9]    | $b\beta_v$ | 0.375000            | [9]        |
| $I_v(0)$ | 56000          | [9]    |            |                     |            |

$$R_0 = \frac{b\beta_v b\beta_h}{\mu_v(\mu_h + \gamma_h)}. \tag{24}$$

### 9. Stability Analysis of Model SIRS for Dengue Fever in South Sulawesi

Stability analysis of the obtained equilibrium values is determined by the Eigenvalues  $\lambda$  [9]. Based on equations (10) and (11), Eigenvalues of the SIRS for the transmission of DF are obtained. The stability of the system, categorized in types as in [20], depends on the Eigenvalues. Model stability analysis of the SIRS model with the initial value in Table 2 is as follows.

The critical value is determined by substituting parameter values of the free disease cases from Table 2. Assuming that equation system (1) is zero, equation system (25) is found as follows:

$$0.000046 - 0.0855 I_v S_h - 0.000046 S_h + 0.575 R_h = 0, \tag{25}$$

$$0.0855 I_v S_h - 0.328879 I_h = 0, \tag{26}$$

$$0.328833 I_h - 0.575046 R_h = 0, \tag{27}$$

$$0.0323 - 0.375 I_h S_v - 0.0323 S_v = 0, \tag{28}$$

$$0.375 I_h S_v - 0.0323 I_v = 0. \tag{29}$$

The Eigenvalues from equations (10) and (11) with parameters described in Table 2 for this SIRS model of the DF transmission are

$$\begin{aligned} \lambda_1 &= -0.000046, \\ \lambda_2 &= -0.0323, \\ \lambda_3 &= -0.575064, \\ \lambda_4 &= -0.328995, \\ \lambda_5 &= -0.032184. \end{aligned} \tag{30}$$

The obtained Eigenvalues  $\lambda$  are real and negatives. Thus, according to [20], the stability of this equilibrium point is asymptotically stable in South Sulawesi. The basic reproduction number using the number of dengue fever in South

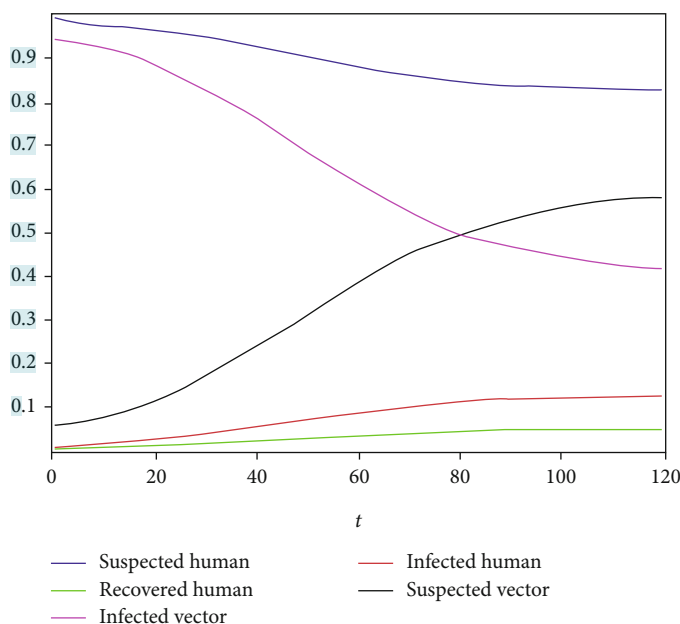

FIGURE 3: Suspected, infected, and recovered prediction of dengue fever in South Sulawesi.

Sulawesi is  $R_0 = 26.47609 > 1$ , which suggests if an infected individual will infect up to 26 others. That means South Sulawesi is in the endemic stage of dengue fever.

### 10. Simulation Result of Model SIRS for DF Transmission in South Sulawesi

Simulation results of the SIRS model toward DF transmissions obtained using the software Maple with initial values and parameters, described in Table 2, are shown in Figure 2. The values are given on the x-axis, while the y-axis shows time (in month) of each of the variables  $S_h(t)$ ,  $I_h(t)$ ,  $R_h(t)$ ,  $S_v(t)$ , and  $I_v(t)$ .

The result of the SIRS model shows if DF transmission requires only very short time to diminish. Based on Figure 3, the number of dengue fever cases (infected humans) in South Sulawesi reaches its peak immediately in six years; meanwhile, the number of suspected humans in South Sulawesi is very high and needs a long time for the decrease. Meanwhile, the number of infected mosquitoes declines four months after its maximum number. Thus, the mosquito population can be reduced quickly in South Sulawesi, and this region becomes endemic to dengue fever. This corresponded to the basic reproduction number value in South Sulawesi  $R_0 = 26.47609 > 1$  and according to Theorem 3; thus, South Sulawesi is endemic to dengue fever.

### 11. Discussion

Studies of the mathematical model of the transmission of dengue fever have been performed by [10], producing the SIR model with analysis using Lyapunov function. In addition, [9] did a simulation of the SIR using data from South Sulawesi, Indonesia, and Selangor, Malaysia. The numerical

solution of the SIRS model for the transmission of DF has been investigated by [8], using the homotopy perturbation method, then [18], producing a SEIRS model with analysis using the Lyapunov function.

This article produces the SIRS model as a modification of the SIR [19], given the fact that recovered individuals from DF will still have a possibility to be suspected. The result of this paper given the analysis of the SIRS is performed using three theorems, namely, the existence, free disease, and endemic DF using the method of Lyapunov function. Simulation results using data from the Health Ministry of the Republic of Indonesia show that South Sulawesi is an endemic area of dengue fever; then, early control and prevention measures need to be done because the climate in Indonesia is increasingly difficult to predict, especially the rainy season which causes many larvae of Aedes mosquitoes spreading dengue virus. The simulation result also can predict the number of suspected, infected, and recovered DF cases in South Sulawesi in the coming months.

### 12. Conclusion

Based on the result and the discussion, the SIRS model for the transmission of DF is obtained. The three theorems produced suggest the existence of DF in a region, free disease status of DF, and the endemic status. The resulted basic reproduction number  $R_0$  is able to predict the possible infected population from an infected DF patient. The simulation result done is able to predict the number of DF cases in South Sulawesi, and the basic reproduction number is  $R_0 = 26.47609 > 1$ ; thus, South Sulawesi is in the endemic stage of dengue fever. The simulation result also as such can be used as a reference to prevent and control the number of dengue fever cases in South Sulawesi.



## Data Availability

The data used to finding support from this paper are available from related author papers as well as online data.

## Conflicts of Interest

The authors declare that they have no conflicts of interest.

## Acknowledgments

We would like to thank UNM No: 558/UN36.11/HK/2020 for the financial support.

## References

- [1] WHO, "Fact sheets: dengue and dengue haemorrhagic fever," 2015, June 2016, <http://www.who.int/mediacentre/factsheets/fs117/en/>, Tribun timur.
- [2] M. Derouich and A. Boutayeb, "Dengue fever: mathematical modelling and computer simulation," *Applied Mathematics and Computation*, vol. 177, no. 2, pp. 528–544, 2006.
- [3] L. Esteva and C. Vargas, "Analysis of a dengue disease transmission model," *Mathematical Biosciences*, vol. 150, no. 2, pp. 131–151, 1998.
- [4] A. Korobeikov, "Lyapunov functions and global properties for SEIR and SEIS epidemic models," *Mathematical Medicine and Biology*, vol. 21, pp. 75–83, 2014.
- [5] G. Li, W. Wang, and Z. Jin, "Global stability of an SEIR epidemic model with constant immigration," *Chaos, Solitons & Fractals*, vol. 30, no. 4, pp. 1012–1019, 2006.
- [6] N. Nuraini, E. Soewono, and K. Sidarto, "Mathematical model of dengue disease transmission with severe dhf compartment," *Bulletin of the Malaysian Mathematical Sciences Society*, vol. 30, no. 2, pp. 143–157, 2007.
- [7] P. Pongsumpun, "Transmission model for dengue disease with and without the effect of extrinsic incubation period," *KMITL Sci. Tech.*, vol. 6, pp. 74–82, 2006.
- [8] Y. M. Rangkuti, S. Side, and M. S. M. Noorani, "Numerical analytic solution of SIR model of dengue fever disease in South Sulawesi using homotopy perturbation method and Variational iteration method," *Journal of Mathematical and Fundamental Sciences.*, vol. 46, no. 1, pp. 91–105, 2014.
- [9] S. Side and S. M. Noorani, "A SIR model for spread of dengue fever disease (simulation for South Sulawesi, Indonesia and Selangor, Malaysia)," *World Journal of Modelling and Simulation*, vol. 9, no. 2, pp. 96–105, 2013.
- [10] S. Syafruddin and M. S. M. Noorani, "Lyapunov function of SIR and SEIR model for transmission of dengue fever disease," *International Journal of Simulation and Process Modelling*, vol. 8, no. 2/3, pp. 177–184, 2013.
- [11] S. Side, W. Sanusi, M. K. Aidid, and S. Sidjara, "Global stability of SIR and SEIR model for tuberculosis disease transmission with Lyapunov function method," *Asian Journal of Applied Sciences*, vol. 9, no. 3, pp. 87–96, 2016.
- [12] E. Soewono and A. K. Supriatna, "A two-dimensional model for the transmission of dengue fever disease," *Bulletin of the Malaysian Mathematical Sciences Society*, vol. 24, pp. 49–57, 2005.
- [13] A. K. Supriatna and E. Soewono, "Model Matematika Penyebaran Penyakit Demam berdarah," *Jurnal Bionatura*, vol. 2, no. 3, pp. 104–116, 2000.
- [14] S. M. O'Regan, T. C. Kelly, A. Korobeinikov, M. J. A. O'Callaghan, and A. V. Pokrovskii, "Lyapunov functions for SIR and SIRS epidemic models," *Applied Mathematics Letters*, vol. 23, no. 4, pp. 446–448, 2010.
- [15] Y. Yaacob, "Analysis of a dengue disease transmission model without immunity," *Matematika*, vol. 23, no. 2, pp. 75–81, 2007.
- [16] G. Z. Zeng, L. S. Chen, and L. H. Sun, "Complexity of an SIR epidemic dynamics model with impulsive vaccination control," *Chaos, Solitons & Fractals*, vol. 26, no. 2, pp. 495–505, 2005.
- [17] K. C. Mozghan and R. Paul, "Simulating heterogeneous behaviours in complex systems on GPUs," *Simulation Modelling Practice and Theory*, vol. 83, pp. 3–17, 2018.
- [18] W. Nur, H. Rachman, N. M. Abdal, M. Abdy, and S. Side, "SIR Model Analysis for Transmission of Dengue Fever Disease with Climate Factors Using Lyapunov Function," *Journal of Physics*, vol. 1028, no. 1, Article 012117, 2018.
- [19] S. Side, A. Zaki, and N. Sari, "A SIRS model for transmission of dengue fever disease in South Sulawesi," in *International Conferences on Mathematics and Natural Sciences*, pp. 81–90, Harris Sunset Road, Kuta Bali, Indonesia, 2017.
- [20] S. Side, W. Sanusi, N. Badwi et al., "A SEIRS model analysis and simulation for dengue fever transmission," *International Journal of Scientific & Technology Research*, vol. 8, no. 10, pp. 1048–1053, 2019.
- [21] O. Diekmann and J. O. P. Hesterbeek, *Mathematical Epidemiology of Infectious Diseases*, John Wiley, Chichester, 2000.
- [22] O. Diekmann, J. A. Heesterbeek, and J. A. J. Metz, "On the definition and the computation of the basic reproduction ratio  $R_0$  in models for infectious diseases in heterogeneous populations," *Journal of Mathematical Biology*, vol. 28, no. 4, pp. 365–382, 1990.
- [23] BPS, "Jumlah Penduduk Sulawesi Selatan," 2018, November 2019, <https://tumorounews.com/2018/04/11/jumlah-penduduk-sulawesi-selatan-terbaru-tahun-2018/>.

● **20% Overall Similarity**

Top sources found in the following databases:

- 13% Internet database
- Crossref database
- 13% Submitted Works database
- 11% Publications database
- Crossref Posted Content database

TOP SOURCES

The sources with the highest number of matches within the submission. Overlapping sources will not be displayed.

|   |                                                                                                |     |
|---|------------------------------------------------------------------------------------------------|-----|
| 1 | <b>docplayer.net</b><br>Internet                                                               | 3%  |
| 2 | <b>erepository.uonbi.ac.ke</b><br>Internet                                                     | 2%  |
| 3 | <b>Khulna University on 2022-03-01</b><br>Submitted works                                      | 2%  |
| 4 | <b>Universitas Negeri Semarang on 2022-10-13</b><br>Submitted works                            | 2%  |
| 5 | <b>doaj.org</b><br>Internet                                                                    | 2%  |
| 6 | <b>scialert.net</b><br>Internet                                                                | 1%  |
| 7 | <b>Syafuruddin Side. "Analysis and Simulation of SIRI Model for Dengue Fe..."</b><br>Crossref  | <1% |
| 8 | <b>W Sanusi, M I Pratama, M Rifandi, S Sidjara, Irwan, S Side. "Numerical ..."</b><br>Crossref | <1% |

|    |                                                                                |                 |     |
|----|--------------------------------------------------------------------------------|-----------------|-----|
| 9  | <b>inderscience.com</b>                                                        | Internet        | <1% |
| 10 | <b>Universitas Pendidikan Indonesia on 2022-01-21</b>                          | Submitted works | <1% |
| 11 | <b>Tewa, J.J.. "Lyapunov functions for a dengue disease transmission mo...</b> | Crossref        | <1% |
| 12 | <b>pdfs.semanticscholar.org</b>                                                | Internet        | <1% |
| 13 | <b>Syafruddin Side, Usman Mulbar, Sahlan Sidjara, Wahidah Sanusi. "A SE...</b> | Crossref        | <1% |
| 14 | <b>digilib.unimed.ac.id</b>                                                    | Internet        | <1% |
| 15 | <b>University of KwaZulu-Natal on 2017-09-01</b>                               | Submitted works | <1% |
| 16 | <b>Excelsior College on 2021-07-08</b>                                         | Submitted works | <1% |
| 17 | <b>mafiadoc.com</b>                                                            | Internet        | <1% |
| 18 | <b>jove.com</b>                                                                | Internet        | <1% |
| 19 | <b>Higher Education Commission Pakistan on 2011-09-17</b>                      | Submitted works | <1% |
| 20 | <b>Universiti Teknologi MARA on 2014-02-03</b>                                 | Submitted works | <1% |

- 21

**Eminugroho Ratna Sari, Nur Insani, Dwi Lestari. "The Preventive Contro...**

Crossref

<1%
- 22

**Hamed Al-Sulami, Moustafa El-Shahed, Juan J. Nieto, Wafa Shammak...**

Crossref

<1%
- 23

**iopscience.iop.org**

Internet

<1%
- 24

**etamaths.com**

Internet

<1%
- 25

**United World College of South East Asia on 2020-11-09**

Submitted works

<1%
- 26

**dspace.nm-aist.ac.tz**

Internet

<1%
- 27

**W. P. T. M. Wickramaarachchi, S. S. N. Perera. "Chapter 3 A Two-Dime...**

Crossref

<1%
- 28

**Bundit Unyong. "THE TRANSMISSION DYNAMICS OF DENGUE FEVER ...**

Crossref

<1%
- 29

**G. Bhuju, G. R. Phaijoo, D. B. Gurung. "Fuzzy Approach Analyzing SEIR-...**

Crossref

<1%
- 30

**Leilei Qu, Qiuhui Pan, Xubin Gao, Mingfeng He. "Population Dynamics o...**

Crossref

<1%
- 31

**S Side, I Sari, W Sanusi. "SEIR Mathematical Model of Seizure fever in I...**

Crossref

<1%
- 32

**Suwardi Annas, Muh. Isbar Pratama, Muh. Rifandi, Wahidah Sanusi, Sy...**

Crossref

<1%

|    |                                                                               |     |
|----|-------------------------------------------------------------------------------|-----|
| 33 | <b>Universitas Pendidikan Indonesia on 2022-02-10</b>                         | <1% |
|    | Submitted works                                                               |     |
| 34 | <b>Universiti Teknologi MARA on 2020-07-19</b>                                | <1% |
|    | Submitted works                                                               |     |
| 35 | <b>Jean Jules Tewa, Jean Luc Dimi, Samuel Bowong. "Lyapunov functions..."</b> | <1% |
|    | Crossref                                                                      |     |
| 36 | <b>Universiti Teknologi MARA on 2017-01-03</b>                                | <1% |
|    | Submitted works                                                               |     |
| 37 | <b>eprints.unm.ac.id</b>                                                      | <1% |
|    | Internet                                                                      |     |

● Excluded from Similarity Report

- Bibliographic material
- Manually excluded text blocks
- Manually excluded sources

EXCLUDED SOURCES

|                                                                                       |            |
|---------------------------------------------------------------------------------------|------------|
| <b>downloads.hindawi.com</b>                                                          | <b>53%</b> |
| Internet                                                                              |            |
| <b>Wahidah Sanusi, Nasiah Badwi, Ahmad Zaki, Sahlan Sidjara, Nurwahidah Sari, ...</b> | <b>52%</b> |
| Crossref                                                                              |            |
| <b>hindawi.com</b>                                                                    | <b>44%</b> |
| Internet                                                                              |            |
| <b>ijstr.org</b>                                                                      | <b>8%</b>  |
| Internet                                                                              |            |
| <b>researchgate.net</b>                                                               | <b>5%</b>  |
| Internet                                                                              |            |

EXCLUDED TEXT BLOCKS

|                                                                                                                 |
|-----------------------------------------------------------------------------------------------------------------|
| <b>HindawiJournal of Applied MathematicsVolume 2021, Article ID</b>                                             |
| Xinhui Cao, Yuting Dong, Zhongzheng Li, Juan Li, Gang Liang, Honglian Zhou. "The Principle of Intelligent Sw... |
| <b>Analysis and Simulation of SIRS Model for Dengue FeverTransmission in South Sul...</b>                       |
| doaj.org                                                                                                        |
| <b>1</b>                                                                                                        |
| Syafruddin Side. "Analysis and Simulation of SIRI Model for Dengue Fever Transmission", Indian Journal of ...   |
| <b>Department, Universitas Negeri Makassar, Makassar 90222, Indonesia</b>                                       |
| doaj.org                                                                                                        |

## Correspondence should be addressed to

Wen-Haw Chen, Ja'faruddin. "Traditional Houses and Projective Geometry: Building Numbers and Projectiv...

---

## 2020; Revised 11 December 2020; Accepted

Georgia College & State University on 2021-03-13

---

## 1. Introduction

Syafruddin Side. "Analysis and Simulation of SIRI Model for Dengue Fever Transmission", Indian Journal of ...

---

## This study is aimed at building and analysing a SIRS model and also simulating the...

doaj.org

---

## Table 1

docplayer.net

---

## Probability of

W. P. T. M. Wickramaarachchi, S. S. N. Perera. "Chapter 3 A Two-Dimensional Dynamical System for Local T...

---

## of spreading virus from Iv to

fmipa.undiksha.ac.id

---

## Analysis of

Syafruddin Side. "Analysis and Simulation of SIRI Model for Dengue Fever Transmission", Indian Journal of ...

---

## Journal of Applied Mathematics3

A. Bustamam, D. Aldila, A. Yuwanda. "Understanding Dengue Control for Short- and Long-Term Intervention ...

---

☒

A. Bustamam, D. Aldila, A. Yuwanda. "Understanding Dengue Control for Short- and Long-Term Intervention ...

---

☒ h☒ hh

A. Bustamam, D. Aldila, A. Yuwanda. "Understanding Dengue Control for Short- and Long-Term Intervention ...

---

## SIRS model diagram of human and vector population

docplayer.net

---

## 2Journal of Applied Mathematics

King Mongkut's Institute of Technology Ladkrabang on 2020-06-12

$\frac{dI}{dt} = \lambda - \beta I S - \mu I$

www.columbia.akadns.net

$\frac{dS}{dt} = \mu - \beta I S - \mu S$

Guihua Li, Zhen Jin. "Bifurcation Analysis in Models for Vector-Borne Diseases with Logistic Growth", The Sc...

### Stability of

Mary C. Swai, Nyimvua Shaban, Theresia Marijani. "Optimal Control in Two Strain Pneumonia Transmission ...

### The derivative of

erepository.uonbi.ac.ke

$\frac{dR}{dt} = \beta I S - \mu R$ ,  $\frac{dS}{dt} = \mu - \beta I S - \mu S$ ,  $\frac{dI}{dt} = \lambda - \beta I S - \mu I$

docplayer.net

$\frac{dI}{dt}$

Jean Jules Tewa, Jean Luc Dimi, Samuel Bowong. "Lyapunov functions for a dengue disease transmission ...

$\frac{dS}{dt}$

Jean Jules Tewa, Jean Luc Dimi, Samuel Bowong. "Lyapunov functions for a dengue disease transmission ...

### Stability Analysis of Model

Syafruddin Side. "Analysis and Simulation of SIRI Model for Dengue Fever Transmission", Indian Journal of ...

$\frac{dI}{dt} = \lambda - \beta I S - \mu I$ ,  $\frac{dS}{dt} = \mu - \beta I S - \mu S$ ,  $\frac{dR}{dt} = \beta I S - \mu R$

Hamed Al-Sulami, Moustafa El-Shahed, Juan J. Nieto, Wafa Shammakh. "On Fractional Order Dengue Epide..."

$\frac{dS}{dt} = \mu - \beta I S - \mu S$ ,  $\frac{dI}{dt} = \lambda - \beta I S - \mu I$ ,  $\frac{dR}{dt} = \beta I S - \mu R$ ,  $\frac{dV}{dt} = \mu - \beta I S - \mu V$ , and  $\frac{dW}{dt} = \mu - \mu W$

Higher Education Commission Pakistan on 2012-07-11

$\frac{dS}{dt} = \mu - \beta I S - \mu S$ ,  $\frac{dI}{dt} = \lambda - \beta I S - \mu I$ ,  $\frac{dR}{dt} = \beta I S - \mu R$ ,  $\frac{dV}{dt} = \mu - \beta I S - \mu V$ ,  $\frac{dW}{dt} = \mu - \mu W$

Higher Education Commission Pakistan on 2012-05-14



## Simulation of SIRS Model for Dengue Fever Transmission in South Sulawesi, Indon...

erepository.uonbi.ac.ke

## humanInfected humanRecovered human

University of Mines and Technology on 2019-05-23

## Suspected, infected, and recovered

Universitas Pendidikan Indonesia on 2022-01-21

## dengue fever.11. DiscussionStudies of the mathematical model of the transmissio...

sq2.ok-em.com

## Data AvailabilityThe data used to finding support

Syafruddin Side. "Analysis and Simulation of SIRI Model for Dengue Fever Transmission", Indian Journal of ...

## Conflicts of InterestThe authors declare that they have no conflicts of interest

Syafruddin Side. "Analysis and Simulation of SIRI Model for Dengue Fever Transmission", Indian Journal of ...

## v

Liming Cai, Xuezhi Li. "Analysis of a Simple Vector-Host Epidemic Model with Direct Transmission", Discrete...

## 1- hS+h

www.aimspress.com

## 1- S h

A. Bustamam, D. Aldila, A. Yuwanda. "Understanding Dengue Control for Short- and Long-Term Intervention ...

## 1- S

Jean Jules Tewa, Jean Luc Dimi, Samuel Bowong. "Lyapunov functions for a dengue disease transmission ...

## Global Stability of Endemic Equilibrium

scialert.net

## h , I h, R h , S v

Peter M. Mwamtobe, Shirley Abelman, J. Michel Tchuenche, Ansley Kasambara. "Optimal (Control of) Interv...

$I_h, R_h, S_v, I$

Guihua Li, Zhen Jin. "Bifurcation Analysis in Models for Vector-Borne Diseases with Logistic Growth", The Sc...

---

$I_h, R_h, S_v, I$

Guihua Li, Zhen Jin. "Bifurcation Analysis in Models for Vector-Borne Diseases with Logistic Growth", The Sc...

---

$\lambda_1 = -\mu h, \lambda_2 = -\mu v$

Excelsior College on 2021-07-08

---

$\gamma h_0$

Universiti Malaysia Terengganu UMT on 2023-02-16

---

$0?-\mu h - \lambda$

Catholic University of Parahyangan on 2020-08-07

---

$\lambda_{000}$

ir.haramaya.edu.et

---

$h_0 - \mu h - \theta h$

Universiti Malaysia Terengganu UMT on 2023-02-16

---

$0??0?? = 0$

Catholic University of Parahyangan on 2020-08-07

---

$v?1 - S_h?Sh$

Anusit Chamnan, Puntani Pongsumpun, I-Ming Tang, Napasool Wongvanich. "Effect of a Vaccination against..."