

PAPER NAME

IJEEDU.pdf

AUTHOR

hendra jaya

WORD COUNT

4701 Words

CHARACTER COUNT

26198 Characters

PAGE COUNT

7 Pages

FILE SIZE

620.1KB

SUBMISSION DATE

Jun 26, 2023 6:01 AM GMT+8

REPORT DATE

Jun 26, 2023 6:02 AM GMT+8

● 10% Overall Similarity

The combined total of all matches, including overlapping sources, for each database.

- 7% Internet database
- 7% Publications database
- Crossref database
- Crossref Posted Content database
- 6% Submitted Works database

● Excluded from Similarity Report

- Bibliographic material
- Quoted material
- Cited material
- Small Matches (Less than 12 words)
- Manually excluded sources
- Manually excluded text blocks

Research Article

Evaluation of the Practicality and Effectiveness of Microcontroller-Based Robotics Trainers as Learning Media

Wahyudi¹, Hendra Jaya², Edy Sabara²

¹Department of Vocational Technology Education, Universitas Negeri Makassar, Makassar 90222, Indonesia

²Department of Electronics Engineering Education, Universitas Negeri Makassar, Makassar 90224, Indonesia

Contact email: wahyudi@unm.ac.id, hendra.jaya@unm.ac.id, edisabara66@unm.ac.id

Received: March 12, 2021; Accepted: April 15, 2021; Published: April 20, 2021

Abstract: The development of robotics technology occurred very rapidly in the industrial era of 4.0. Human interest in robot development is getting higher, and research related to robotics is increasingly emerging. One of these developments is the research of learning media, one of which is a robotics trainer. A robot is a mechanical device that can perform physical tasks, either using human supervision and control or using a program that has been logged in in the form of artificial intelligence. Based on this, a research study aimed to determine the stages of developing a microcontroller-based robotics trainer media as a learning medium at Universitas Negeri Makassar and producing a robotics trainer media that is valid, practical, and effective. The research method used is Research and Development (R&D) with the 4D development model theory, namely (1) defining, (2) designing, (3) development, (4) spreading. This study indicates that the microcontroller-based robotics trainer media developed on the media and material aspects are in the very right category to be used. The media trainer's implementation received student responses in the practical class, its use, and the results of student test scores after the performance had increased to be in the high category. The conclusion of these data states that the microcontroller-based robotics trainer media that has been developed is declared valid/suitable for use and practical and effective in its use.

Keywords: Atmel AVR, Arduino, Bluetooth and IoT Connection, Education Media, Learning Materials.

1. Introduction

The era of the 4.0 generation industrial revolution is characterized by increased connectivity, interaction and development of digital systems, artificial intelligence, and virtual. With the increasing convergence of boundaries between people, machines and other resources, information and communication technology certainly impact on various sectors of life [1], [2]. One of them is the impact on the educator system. Education is a process that happens to every human being. Naturally, humans grow and develop from the womb until death, undergoing a

step-by-step process [3]. Similarly, the events of the universe were created by God through a level-by-level process. So, education plays a role in shaping the good or bad of human beings according to normative measures. Realizing this, the government is very serious about improving the education system, because with a good education system is expected to emerge the next generation of qualified and able to adjust to the life of society, nation, and state. Education in the sense of being a conscious effort to prepare learners through mentoring, teaching, and/or training activities for their role in the

This Article Citation: Wahyudi, H. Jaya, E. Sabara, "Evaluation of the Practicality and Effectiveness of Microcontroller-Based Robotics Trainers as Learning Media," *Int. J. Environ. Eng. Educ.*, vol. 3, no. 1, pp. 25-31, 2021.

future. Even the notion of education is broader as an activity and phenomenon.

Learning as a process is a system that involves various parts such as educators, students, teaching materials, learners, learning resources, learning media, and methods [4]. The success of learning is determined if the learning can develop the potentials that students have, so that students can benefit directly in their personal development. The responsibility of learning success lies in the hands of a teacher [5]. This means that a teacher should make every effort to organize the learning process in such a way that the necessary components of the learning can interact between all components. The success of a learning process is determined by several components that affect it. These components include objectives, teachers, students, methods, media (facilities and infrastructure), as well as evaluation and all components are interconnected so that it is easy to achieve the goals to be achieved.

An era of rapid technological and educational change, and adapting and responding to changes that require new knowledge, skills, and dispositions. Such diversity means that teachers' work is in flux, and the teaching and learning process must be flexible and adaptive to support the process of change [6]. The rapid development of science and technology today, has brought about a very rapid change in various aspects of life. Jobs and the way we work is changing, a lot of jobs are missing, while different types of new jobs are popping up. Economic, social, and cultural changes are also occurring at a high rate. In this very dynamic time, universities must respond quickly and appropriately. Learning transformation is needed to be able to equip and prepare higher education graduates in order to become a superior generation [7]. A generation that is responsive and ready to face the challenges of its time, without being divorced from the cultural roots of its people.

Vocational education is basically an education to develop or drive economic activities, because vocational education is designed to meet the needs of the job market and this will contribute positively to the productive world of work that produces goods and commodities that have economic value, then collectively a productive workforce capable of producing goods of accumulative value will drive the wheels of the economy and this affects national economic growth [8], [9].

Learning materials in learning is one of the components that must exist, because learning materials are several components that must be studied, observed, studied, and made materials that will be mastered by students and at the same time can provide instructions to learn them [10]. Without learning materials, learning will not produce anything. Learning Materials are external factors that can be supported by internal motivation to

learn. One of the learning events that can influence learning activities by including learning materials in the activity. Formally designed learning materials complete in the sense that there are adequate media and learning resources will have an impact on learning the learning process that occurs in students to be more optimal. Well-designed learning materials with interesting content and illustrations will stimulate students to use learning materials as learning materials or as learning resources.

Learning media is an important component in supporting the learning process. The existence of learning media will make it easier for lecturers to deliver learning materials and students easier to learn. This learning media can be reproduced/produced that aims to make the resulting learning media can be applied to students. Charles Prosser, believes that science cannot be moved from one field of learning to another, and learning will be effective if implemented specifically and directly on the problem [11]. Charles Prosser distinguishes between general secondary education and vocational secondary education. Charles Prosser also introduced schools for work, where students are brought in to learn exercises and projects such as real working conditions in the industry [12].

A robot that is one of the electro-mechanical or bio-mechanical equipment, or a combination of equipment that produces autonomous movement or movement based on movement ordered using a programming language that is widely used in today's industry. Robots are usually programmed to perform repetitive work (loops) and have mechanisms guided by automatic control [13], [14]. While robotics is basically a science that learns about robots, so Robotic or robotics has the definition of a branch of technology related to the design, construction, operation, structural disposition, manufacture, and application of robots. Robotics is related to the science of electronics, machinery, mechanics, and computer software [15], [16]. Learning media on the market tends to be very common, so it is less supportive of students' use as a teaching medium in the learning process. In addition, students do not yet have a working step module in the learning process of teaching robotics practice courses.

Microcontrollers in their use can be found in various home appliances, such as appliances contained in the home, such as digital telephones, microwave ovens, televisions, washing machines, home security systems, PDAs [17]. Microcontrollers can be used for various applications for controllers, industrial automation, data acquisition, telecommunications, and others [18]. The advantage of using a microcontroller is that it is cheap, can be programmed repeatedly, and we can program according to our wishes. Currently the microcontroller families in the market are Intel 8048, and 8051(MCS51),

Motorola 68HC11, Microchip PIC, Hitachi H8, and Atmel AVR. The development of microcontrollers today is very widely used Arduino. Arduino is said to be a platform of physical computing that is open source. Arduino is not just a device/hardware but Arduino is a combination of hardware and software and integrated development environment (IDE) that is very open and has many references. So, in the development of robotics media trainers are very suitable in the selection of microcontrollers to be used.

The background of the problems that have been stated above, the development of learning media of robotics practice courses is considered important, because the related issues that can be identified are 1) The urgent need for lecturers and students to media the learning of robotics practice courses for students in order to meet the demands of learning. Charles Prosser's theory that learning will be effective if implemented specifically and directly on the problem by following replicas that exist in the industry [11].

18
2. Research Methods

2.1. Research Approach

The type of research used is Research and Development (R&D). Research and Development method or called research and development is a research method used to produce products and test the validity, practicality, and effectiveness of the product [19]. This research will be conducted using the development of 4D Models namely (1) Definition, (2) Planning, (3) Development, (4) Deployment. From this research is expected to produce learning device products in the form of media trainer microcontroller Respondent-based robotics system that is valid, practical, and effective.

2.2. Sample and Material

The population of this research is students of Mechatronics Vocational Education at the Faculty of Engineering, Universitas Negeri Makassar. Some of the research samples needed include one to one trial of 3 (three) people, small group trials of 5 (five) people, and field trials of 19 people.

Then this research material is a Microcontroller Respondent-based Robotics Media Trainer. This trainer contains Arduino Uno and Node MCU controls and interfaces Such as Robotic Arm, Line Follower Robot, Ultrasonic Sensor (Wall Follower Robot) Fire Sensor & Fan (Fire Extinguishing Robot), Flying Robot and Network Robot as well as additional devices as connection and control of the robot. This trainer was developed by combining all devices into one integrated board to facilitate the practical process.

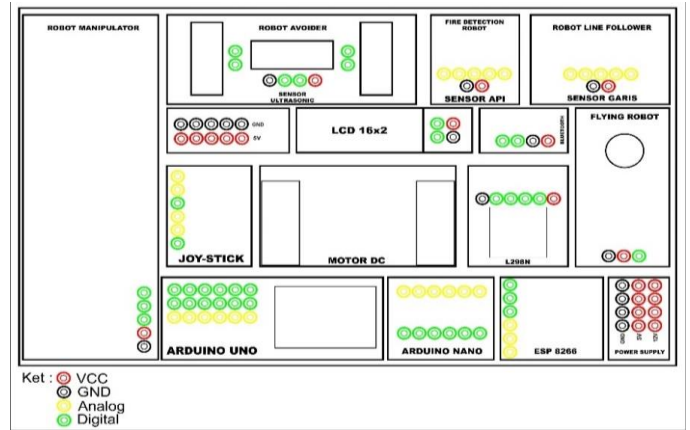

Figure 1. Layout of Robotics Trainer Media.

Series creation using the application of making a series/module component to be used in the manufacture of trainers, the first thing to do is to choose the appropriate components in the manufacture of trainers. So that the placement of components and other devices in accordance with the size of trainers that have been made before.

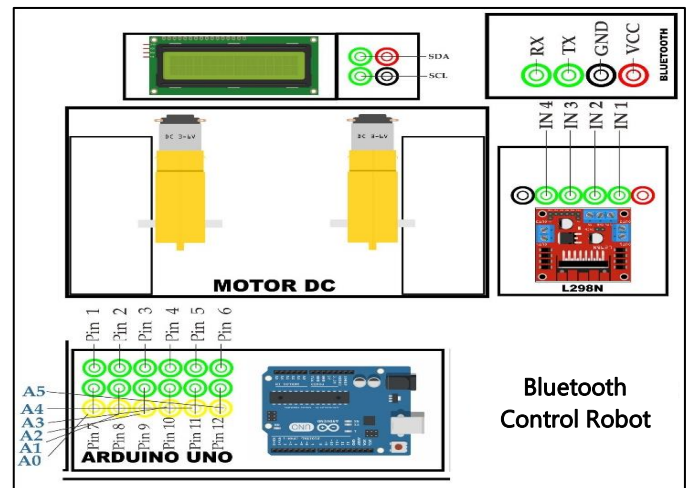

Figure 2. Robotics Trainer Media Circuit.

Trainer is a very important tool in practicum, usually Trainers used in practicum do not need a program, but trainers that are made need a program to be able to communicate, the software used to create programs is the Arduino IDE, this software is designed to make programs using the C language. used to define the Arduino pin and the Node MCU pin must be in accordance with the circuit that has been made, these pins function to control the input value of the sensor and provide output to the devices on the trainer.

After designing the trainer, an Android application was also designed to function as Bluetooth communication and long-distance communication with robotic trainers. After the trainer has been completed, a

learning module or guide module will be made based on the composition of the material that has been made.

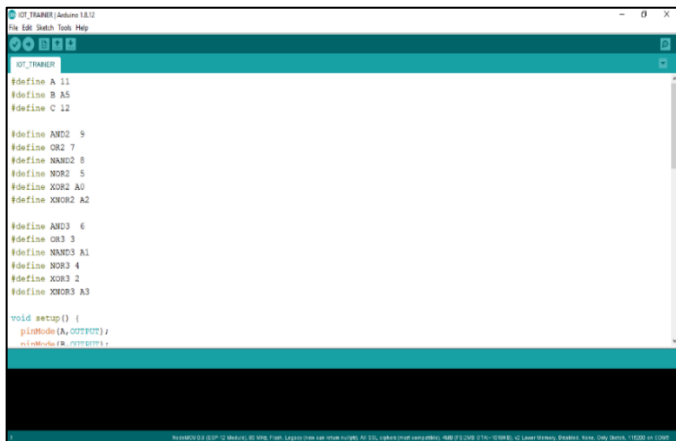

Figure 3. Robotics Trainer Media Programming



Figure 4. Robotics Trainer Media

2.3. Data Collection Techniques

The quality of the instrument determines the quality of the data collected later. To get a good instrument and obtain information about the validity, practicality, and effectiveness of trainers, researchers use the following instruments:

- Validation Questionnaire

Validation questionnaires are used to obtain information about whether a product has been developed to support the defense process. Divided into two parts, namely media validation questionnaires of microcontroller Respondent-based robotics trainers and validation questionnaires of module materials for the use of microcontroller Respondent-based robotics trainers for users. The product being tested was later revised. The expert validator performs evaluations, provides corrections and suggestions on the devices used.

- Questionnaire

Questionnaire is a list of written questions that require responses both conformity and discrepancy of the attitude. Questions and statements written on the questionnaire are based on indicators derived on each variable. The contribution of thought is very meaningful for the development of the concept of a systematic approach in determining the truth. This instrument is used to see the response of learners to know the expertise of trainers that have been developed.

- Test

Tests are conducted at the beginning and end of the material and in the form of summative tests to measure competency achievement. The test model that will be presented is choice (multiple choice) to know the extent of the student's ability after the product is tested. This test is intended to determine the effectiveness of microcontroller Respondent-based robotics trainers developed by looking at the assignment and understanding of the materials that have been delivered.

19 2.4. Data Analysis

The data analysis technique in this study is to use descriptive percentage analysis that describes the results of development, validator response, one to one trial results, small group trials and large group trials. These types of data analysis are described in more detail to answer each research question as follows:

- Microcontroller-based Robotics Trainer Practicality Data Analysis.

The analysis of practicality data was obtained by considering the student response data obtained from the student response questionnaire to the Microcontroller-based Robotics Trainer. To state the practicality of the learning model products developed are analyzed descriptively with the criteria that have been modified contained in the following table:

Table 1. Practicality Criteria

Score	Criteria	Category
85.01% - 100%	Very Practical	Very well used
70.01% - 85.00%	Quite Practical	Pretty well used
50.01% - 70.00%	Less Practical	Not good to use
01.00% - 50.00%	Impractical	Not good to use

- Microcontroller-Based Robotics Trainer Effectiveness Data Analysis.

The test sheet²⁰ in the form of pretest and posttest is given to students to measure the success of the implementation of Microcontroller-Based Robotics Trainer developed will

be analyzed descriptively by showing students' grades before and after the implementation of Microcontroller-Based Robotics Trainer. The category of N-gain score can be determined based on N-gain value [20], as follows:

Table 2. N-Gain Effectiveness Category

N-Gain Score	Category
$G > 0.70$	High
$0.30 \leq G \leq 0.70$	Moderate
$G < 0.30$	Low

3. Result and Discussions

The practicality test phase is divided into three types of trials, namely one to one trial, small group trials and large groups. Small group trials involve 5 (five) learners to see their response and understanding after using microcontroller Respondent-based robotics trainers, if there is a good percentage of response then proceed to testing in large groups, if the implementation results are still below well then revisions will be made to be retested in small groups.

A large group of 19 people, the implementation is carried out the same as the implementation on the one-to-one test and a small group. The practicality of microcontroller Respondent-based robotics trainer media is determined by the instrument fill value, while the instrument used is an instrument that has been validated first by experts. The instrument contains four aspects of refining, namely the aspects of application, appearance, content/ content, and language. Instruments will be given at 2 (two) stages, namely in small groups and large groups.

4.1. One to One Testing

One to one trial involves 3 (three) students as test subjects. The trial was conducted by means of researchers providing general explanations in the form of media introduction, module introduction, and installing applications on laptops and smartphones for Bluetooth connection and IoT connection. After the student successfully conducted the installation followed by the provision of introductory material on microcontroller Respondent-based robotics, the material is explained starting from 1 (one) introductory material to 8 (eight) experiments. Furthermore, 3 (three) students were asked to fill out an instrument questionnaire containing research columns and comments on microcontroller Respondent-based robotics media.

Based on Table 3 recapitulation of one-to-one trials obtained an average aspect of the application 89.58%, display 93.75%, content 84.52% and language 86.11%, so it can be concluded that microcontroller Respondent-

based robotics trainer media is in the category is very practical so that it can be continued to small group trials.

Table 3. Recapitulation Results from Pilot One to One

Aspect	Test Respondents (%)			Average (%)
	R-1	R-2	R3	
Application/ Device	93.75	81.25	93.75	89.58
Display	87.50	93.75	100.00	93.75
Content	85.71	78.57	89.29	84.52
Language	83.33	75.00	100.00	86.11

4.2. Small and Large Group Testing (Practical Test)

Small group trials involve 5 (five) students as test subjects. The trial was conducted by means of researchers providing general explanations in the form of media introduction, module introduction, and installing applications on laptops and smartphones for Bluetooth connection and IoT connection. After the student successfully conducted the installation followed by the provision of introductory material on microcontroller Respondent-based robotics, the material is explained starting from 1 (one) introductory material to 8 (eight) experiments. Furthermore, 5 (five) students were asked to fill out an instrument questionnaire containing research columns and comments on microcontroller Respondent-based robotics media.

Large group trials involved 19 (nineteen) students as test subjects. The trials were conducted similarly to the process in small group trials, researchers gave general explanations in the form of media introduction, module introduction, and installing applications on laptops and smartphones for Bluetooth connection and IoT connection. After the student successfully conducted the installation followed by the provision of introductory material on microcontroller Respondent-based robotics, the material is explained starting from 1 (one) introductory material to 8 (eight) experiments. Furthermore, the 19 students were asked to fill out an instrument questionnaire containing research columns and comments on microcontroller Respondent-based robotics media.

Based on Table 4 recapitulation of small group trials obtained an average aspect of the application 90.00%, display 92.50%, content 91.43% and language 93.33%, so it can be concluded that microcontroller Respondent-based robotics trainer media is in the category is very practical so that it can be continued to large group trials. For the recapitulation of large group trials obtained the average aspect of the application 91.67%, display 95.83%, content 91.67% and language 91.67%, so it can be concluded that microcontroller Respondent-based robotics trainer media is in the category is very practical.

Table 4. Recapitulation Results from Pilot One to One Small and Large Group Testing

Aspect	% Average Group Test Results	
	Small Group	Large Group
Application/ Device	90.00	91.67
Display	92.50	95.83
Content	91.43	91.67
Language	93.33	91.67

4.3. Testing the Effectiveness of Learning Media

Large groups in addition to the assessment of media practicality are also conducted data retrieval to know the effectiveness of the media. Effectiveness data obtained from the provision of training tests or training questions to students before and after the use of microcontroller Respondent-based robotics trainers. Before using the media, students were given multiple choice exercises as many as 30 questions done within 40 minutes (pre-test) and after using the media students were given back the same exercises with a different order of questions than before that were done within 40 minutes as well (post-test). The data obtained from this activity will determine the level of practicality of microcontroller Respondent-based robotics media and the results of the data can be seen in the following table.

Table 5. Recapitulation of the results of pre-test and post-test

Respondents	Score Pre-test	Score Post-test
Respondent-01	43.33	90.00
Respondent-02	40.00	86.67
Respondent-03	50.00	93.33
Respondent-04	40.00	90.00
Respondent-05	43.33	76.67
Respondent-06	43.33	93.33
Respondent-07	33.33	90.00
Respondent-08	63.33	80.00
Respondent-09	23.33	83.33
Respondent-10	33.33	86.67
Respondent-11	23.33	90.00
Respondent-12	43.33	80.00
Respondent-13	66.67	90.00
Respondent-14	66.67	96.67
Respondent-15	43.33	80.00
Respondent-16	43.33	86.67
Respondent-17	30.00	76.67

Respondents	Score Pre-test	Score Post-test
Respondent-18	40.00	70.00
Respondent-19	33.33	76.67

Based on Table 5 obtained the highest score on the pretest is 66.67 with the average student score is 47.01, and on the posttest obtained the highest score is 96.6 with the average student score is 79.82.

A normalized gain test (N-Gain) was conducted to determine the improvement of students' cognitive learning outcomes after treatment. This increase is taken from the pretest and posttest scores that are called by students. Normalized gain or abbreviated as N-Gain is a comparison of the actual gain score with the maximum gain score [21]. The actual gain score is the gain score obtained by the student while the maximum gain score is the highest possible gain score for the student. The calculation of gain normalization (N-Gain) score can be expressed in the following formula:

$$N - Gain = \frac{Score\ Posttest - Score\ Pretest}{Score\ Max - Score\ Pretest} \quad (1)$$

From the calculation obtained N-Gain value of 0.77 or in the high category, so it can be concluded that microcontroller-based robotics trainers have been effective in their use. Learning media is a means of delivering learning messages in relation to the direct learning model, namely by the way the teacher acts as a conveyor of information and in this case the teacher should use a variety of suitable media. Learning media is a tool for the teaching and learning process. Everything that can be used to stimulate thoughts, feelings, attention and abilities or skills of learners to encourage the learning process [22], [23].

For the teaching and learning process to be successful, students should be invited to take advantage of all the sensory organs [24]. The teacher tries to display stimuli or stimuli that can be processed by various senses. The more sensory organs used to receive and process information, the more likely it is that the information will be understood and can be retained in memory [25]. Thus, students are expected to receive and absorb well and easily the messages in the material presented. Levie and Levie concluded that visual stimuli produced better learning outcomes for tasks such as remembering, recognizing, and correlating facts and concepts [26]. Verbal stimuli provide more learning outcomes when learning involves sequential memory. Therefore, learning using multiple senses, namely sight and hearing will benefit students. Students will learn more material presented with sight and hearing stimuli.

4. Conclusion

Learning media is a component of learning resources or physical vehicles that contain instructional material in the student environment that can stimulate students to learn. To produce a quality learning process, there are many aspects that influence it. These aspects include professional teachers, teaching methods, conditions and learning conditions that are conducive to learning, and the use of instructional media. Variations in learning media should be able to create a quality learning process. Further research development can further deepen the knowledge of the Internet of Robotic Things and artificial intelligence (AI) in the use of microcontrollers, because the Internet of Robotic Things and AI are one of the areas of science that are very much needed in the era of the industrial revolution 4.0.

Acknowledgments

This research is supported by the Postgraduate Program, Universitas Negeri Makassar. Thanks to the Mechatronics Vocational Education Study Program, Makassar State University for the opportunity given until this research can be completed.

References

- [1] M. Dopico, A. Gómez, D. De la Fuente, N. García, R. Rosillo, and J. Puche, "A vision of industry 4.0 from an artificial intelligence point of view," in *Proceedings on the international conference on artificial intelligence (ICA)*, 2016, p. 407.
- [2] K. Schwab, *The fourth industrial revolution*. Currency, 2017.
- [3] A. Selamat, R. A. Alias, S. N. Hikmi, M. Puteh, and S. M. Tapsi, "Higher education 4.0: Current status and readiness in meeting the fourth industrial revolution challenges," *Redesigning High. Educ. Towar. Ind.*, vol. 4, pp. 23–24, 2017.
- [4] J. Mezirow, "A critical theory of adult learning and education," *Adult Educ.*, vol. 32, no. 1, pp. 3–24, 1981.
- [5] M. Kapur, "Examining productive failure, productive success, unproductive failure, and unproductive success in learning," *Educ. Psychol.*, vol. 51, no. 2, pp. 289–299, 2016.
- [6] C. Dede, "Technological supports for acquiring 21st century skills," *Int. Encycl. Educ.*, vol. 3, pp. 158–166, 2010.
- [7] P. Mishra and M. J. Koehler, "Introducing technological pedagogical content knowledge," in *annual meeting of the American Educational Research Association*, 2008, pp. 1–16.
- [8] T. Agrawal, "Vocational education and training programs (VET): An Asian perspective.," *Asia-Pacific J. Coop. Educ.*, vol. 14, no. 1, pp. 15–26, 2013.
- [9] A. Anlezark, T. Karmel, and K. Ong, *Have school vocational education and training programs been successful?* National Centre for Vocational Education Research, 2006.
- [10] I. Forsyth, *Teaching and learning materials and the Internet*. Routledge, 2014.
- [11] L. S. Hawkins, C. A. Prosser, and J. C. Wright, *Development of vocational education*. American Technical Society, 1967.
- [12] C. A. Prosser and C. R. Allen, *Vocational education in a democracy*. Century Company, 1925.
- [13] Z. Pan and H. Zhang, "Robotic machining from programming to process control: a complete solution by force control," *Ind. Robot An Int. J.*, 2008.
- [14] R. P. Paul, *Robot manipulators: mathematics, programming, and control: the computer control of robot manipulators*. Richard Paul, 1981.
- [15] S. Nolfi and D. Floreano, *Evolutionary robotics: The biology, intelligence, and technology of self-organizing machines*. MIT press, 2000.
- [16] B. Siciliano and O. Khatib, *Springer handbook of robotics*. springer, 2016.
- [17] R. Shahriyar, E. Hoque, S. M. Sohan, I. Naim, M. M. Akbar, and M. K. Khan, "Remote controlling of home appliances using mobile telephony," *Int. J. Smart Home*, vol. 2, no. 3, pp. 37–54, 2008.
- [18] N. M. Morshed, G. M. Muid-Ur-Rahman, M. R. Karim, and H. U. Zaman, "Microcontroller based home automation system using Bluetooth, GSM, Wi-Fi and DTMF," in *2015 International Conference on Advances in Electrical Engineering (ICAEE)*, 2015, pp. 101–104.
- [19] S. Laws, C. Harper, N. Jones, and R. Marcus, *Research for development: A practical guide*. Sage, 2013.
- [20] D. E. Meltzer, "The relationship between mathematics preparation and conceptual learning gains in physics: A possible 'hidden variable' in diagnostic pretest scores," *Am. J. Phys.*, vol. 70, no. 12, pp. 1259–1268, 2002.
- [21] R. R. Hake, "Analyzing Change/Gain Score." USA: Macmillan Publishing, 1999.
- [22] T. Tofade, J. Elsner, and S. T. Haines, "Best practice strategies for effective use of questions as a teaching tool," *Am. J. Pharm. Educ.*, vol. 77, no. 7, 2013.
- [23] R. Ritchhart, M. Church, and K. Morrison, *Making thinking visible: How to promote engagement, understanding, and independence for all learners*. John Wiley & Sons, 2011.
- [24] R. Smilkstein, *We're Born to Learn: Using the Brain's Natural Learning Process to Create Today's Curriculum*. Corwin Press, 2011.
- [25] H. Gardner, *Disciplined mind: What all students should understand*. Simon & Schuster, 2021.
- [26] W. H. Levie and R. Lentz, "Effects of text illustrations: A review of research," *Ectj*, vol. 30, no. 4, pp. 195–232, 1982.



● **10% Overall Similarity**

Top sources found in the following databases:

- 7% Internet database
- Crossref database
- 6% Submitted Works database
- 7% Publications database
- Crossref Posted Content database

TOP SOURCES

The sources with the highest number of matches within the submission. Overlapping sources will not be displayed.

1	repository.uin-malang.ac.id Internet	<1%
2	Purnamawati, R T Mangesa, Ruslan, Idhar. "Development of Learning ... Crossref	<1%
3	dweepunya.blogspot.com Internet	<1%
4	github.com Internet	<1%
5	ejournal.unima.ac.id Internet	<1%
6	journal.unnes.ac.id Internet	<1%
7	INTI International University on 2012-06-29 Submitted works	<1%
8	Padjadjaran University on 2018-01-26 Submitted works	<1%

9	Faisol Hidayatulloh, M Farid Nasrulloh, Fitri Habibah. "Development of ...	<1%
	Crossref	
10	jurnal.unimed.ac.id	<1%
	Internet	
11	giapjournals.com	<1%
	Internet	
12	territoinsular.org	<1%
	Internet	
13	A P S Budi, W Sunarno, Sugiyarto. "Natural science modules with SETS...	<1%
	Crossref	
14	S Maharani, E Suprpto. "Developing group investigation-based book o...	<1%
	Crossref	
15	Yasser Djawad, Ridwansyah Ridwansyah, Suhartono Suhartono, Hendr...	<1%
	Crossref	
16	journal2.um.ac.id	<1%
	Internet	
17	Universitas Riau on 2017-11-22	<1%
	Submitted works	
18	seminar.uad.ac.id	<1%
	Internet	
19	un-pub.eu	<1%
	Internet	
20	D Ambarwati, A Suyatna, C Ertikanto. "The Effectiveness of Interactive ...	<1%
	Crossref	

-
- 21 **Muhammad Darwis, Yulia Anita Siregar, Aisyah Karimah Siregar, Laila ...** <1%
Crossref

 - 22 **id.scribd.com** <1%
Internet

● Excluded from Similarity Report

- Bibliographic material
- Cited material
- Manually excluded sources
- Quoted material
- Small Matches (Less than 12 words)
- Manually excluded text blocks

EXCLUDED SOURCES

eprints.unm.ac.id	92%
Internet	
researchgate.net	12%
Internet	
aasvet2021.yuntech.edu.tw	11%
Internet	
jurnal.fkip.unila.ac.id	9%
Internet	
garuda.kemdikbud.go.id	6%
Internet	
media.neliti.com	2%
Internet	
eudl.eu	2%
Internet	
General Sir John Kotelawala Defence University on 2019-09-14	2%
Submitted works	
atlantis-press.com	2%
Internet	

journal.unj.ac.id	2%
Internet	
doaj.org	2%
Internet	
ijeeedu.com	2%
Internet	
Chelsy Marcella. "The Effectiveness of The Use Game Based Learning on Stu...	2%
Crossref	
ieomsociety.org	2%
Internet	
iccd.asia	1%
Internet	
prospek.unram.ac.id	1%
Internet	
journal2.uad.ac.id	1%
Internet	
files.eric.ed.gov	1%
Internet	
Universitas Negeri Padang on 2019-03-28	1%
Submitted works	
Universitas Negeri Padang on 2019-03-28	1%
Submitted works	
int-jecse.net	1%
Internet	

primary.ejournal.unri.ac.id	1%
Internet	
novateurpublication.com	1%
Internet	
Forum Perpustakaan Perguruan Tinggi Indonesia Jawa Timur II on 2021-11-20	1%
Submitted works	
Universitas Jember on 2020-12-04	<1%
Submitted works	
Universitas Jember on 2020-11-11	<1%
Submitted works	
zenodo.org	<1%
Internet	
cdn.undiksha.ac.id	<1%
Internet	
repository.lppm.unila.ac.id	<1%
Internet	
Yuniarti Maya, Erikson Saragih. "The Utilization of Animation in the Theory of ...	<1%
Crossref	
journals.aiac.org.au	<1%
Internet	
ummaspul.e-journal.id	<1%
Internet	
jcreview.com	<1%
Internet	

archive.org	<1%
Internet	
<hr/>	
O Dermawan, Defriyanto, Junaidah, S M Ayu, Busmayaril, Meisuri, M.J Muht...	<1%
Crossref	
<hr/>	
ijstr.org	<1%
Internet	
<hr/>	
dinastipub.org	<1%
Internet	
<hr/>	
coursehero.com	<1%
Internet	
<hr/>	
journaljesbs.com	<1%
Internet	
<hr/>	
S Arianti, I M Astra, E Budi. "Design of Virtual Physics Laboratory (VPL) on Col...	<1%
Crossref	
<hr/>	
Universitas Negeri Jakarta on 2023-04-12	<1%
Submitted works	
<hr/>	
repo.budiutomomalang.ac.id	<1%
Internet	
<hr/>	
repository.unej.ac.id	<1%
Internet	
<hr/>	
e-journal.undikma.ac.id	<1%
Internet	

EXCLUDED TEXT BLOCKS

2021 Evaluation of the Practicality and Effectiveness of Microcontroller-Based Rob...

ojs.unm.ac.id

International Journal of Environment, Engineering & Education, vol. 3, no

zenodo.org

is a means of delivering learning messages

journal.stkipsingkawang.ac.id

Learning Materials are external factors that can

Muhammad Darwis, Yulia Anita Siregar, Aisyah Karimah Siregar, Laila Tussifah Lubis, Herman Pelangi, Muly...

comparison of

commons.hostos.cuny.edu

by increased connectivity, interaction and development of digital systems, artificial ...

journal.kapin.org

In this very dynamic

online-journal.unja.ac.id
