

# Response Surfaces of Linoleic Acid of Swietenia Mahagoni

*by* Rachmawaty Rachmawaty

---

**Submission date:** 15-Dec-2018 12:39PM (UTC+0700)

**Submission ID:** 1057481297

**File name:** Hartati\_2018\_J.\_Phys.%3A\_Conf.\_Ser.\_1028\_012011.pdf

**Word count:** 3098

**Character count:** 15655

PAPER • OPEN ACCESS

## Response Surfaces of Linoleic Acid of *Swietenia Mahagoni* in Supercritical Carbon Dioxide

To cite this article: Hartati *et al* 2018 *J. Phys.: Conf. Ser.* **1028** 012011

View the [article online](#) for updates and enhancements.

### Related content

- [Relative permittivity behavior and temperature changes in linoleic acid during the phase transition](#)  
R Kociesza, R M Siegoczycki, A J Rostocki *et al.*
- [Application of Response Surface Methodology \(RSM\) for wastewater of hospital by using electrocoagulation](#)  
Murdani, Jaktar, D Ekawati *et al.*
- [Supercritical carbon dioxide for textile applications and recent developments](#)  
H A Eren, O Avinc and S Eren



**IOP | ebooks™**

Bringing you innovative digital publishing with leading voices to create your essential collection of books in STEM research.

Start exploring the collection - download the first chapter of every title for free.

## Response Surfaces of Linoleic Acid of *Swietenia Mahagoni* in Supercritical Carbon Dioxide

Hartati<sup>1\*</sup>, Liza Md Salleh<sup>2</sup>, Halifah Pagarra<sup>1</sup>, Rachmawaty<sup>1</sup>

<sup>1</sup> Department of Biology, Faculty of Mathematics and Natural Sciences, Universitas Negeri Makassar, Makassar 90222, Indonesia

<sup>2</sup> Department of Bioprocess Engineering, Faculty of Chemical Engineering, Universiti Teknologi Malaysia, 81310 UTM Johor Bahru, Malaysia

\*hartati@unm.ac.id

**Abstract.** The process variables pressure, temperature and particle size were studied for optimization of linoleic acid by response surface methodology following a Box-Behnken design of experiments. The results indicated the effect of extraction condition on linoleic acid of the extracts produced SC-CO<sub>2</sub> gave the different effect. But, Analysis of the variance of the data indicated that there was no statistically significant difference between the other sample. Although there was greater variation within the sample, there was still no statistically significant effect of temperature and pressure on the extraction. The optimum conditions for linoleic acid yield from *Swieteniamahagoni* seed within the experimental range were found to be pressure of 29.02 MPa, a temperature of 67.88°C and particle size 0.75 mm, and the predicted linoleic acid was found to be 34.91%.

### 1. Introduction

*Swietenia mahagoni* seeds have been applied as folk medicine for the treatment of hypertension, malaria, and diabetes [1]. There have also been reports of *S. mahagoni* seeds having anti-inflammatory, antimutagenicity, antitumor [2], antioxidant and antimicrobial activities [3]. The therapeutic effects associated with the seeds are mainly caused by the biologically active ingredients; fatty acids and tetranortriterpenoids [4].

Supercritical carbon dioxide extraction (SC-CO<sub>2</sub>) is an alternative technique to conventional extraction of lipids with organics solvents. Moreover, carbon dioxide as a solvent possesses many advantages (nontoxic, nonflammable, inexpensive and yields high purity oil) which can be successfully explored in food and pharmaceutical application [5,6,7]. SC-CO<sub>2</sub> was successfully used in the extraction of edible oils from a wide range of seeds, including hiprose [8], cuphea [9], flax [10], amaranth [11], sunflower and rape [12], *Swietenia mahagoni* [13]. Previous studies on SC-CO<sub>2</sub> of *S. mahagoni* seeds were mainly focused on the determination of total oil contents in ground seeds [13].

Response surface methodology (RSM) is a statistical technique, which is used to evaluate the effect of multiple factors and their interaction on one or more response variables. Recently, RSM has been successfully applied to optimize SC-CO<sub>2</sub> extraction of oils from *Swietenia mahagoni* seed [13], *Salvia mirzayanii* [14], Passiflora seed [15], Silkworm pupae [16], wheat germ [17], cotton seed [18], Curcuma longa [19], rosehip seed [20], *Cyperus rotundus* [21], and amaranth seed [22]. In the present



study, SC-CO<sub>2</sub> was used to extract the oil from *S. mahagoni* seed. The aim was to investigate the influence of supercritical carbon dioxide parameter on the linoleic acid on *S. mahagoni* seeds extract.

## 2. Experimental Details

A schematic flow diagram of the extraction apparatus is shown in Figure 1. *S. mahagoni* seed oil was extracted with supercritical carbon dioxide. The ground sample of 5 g was placed in an extractor vessel. The extracts were collected in a glass vial placed in the separator at ambient temperature and pressure. A flow rate of CO<sub>2</sub> was 2 mL/min. The investigated values of pressure, temperature, and particle size were varied from 20 to 30 MPa, 40 to 60°C, and 0.25 to 0.75 mm, respectively. After each extraction, the obtained extract was placed into glass vials, sealed and stored at 4°C to prevent any possible degradation.

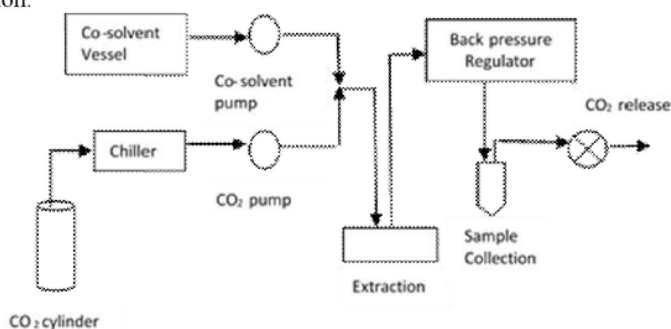

**Figure 1.** A schematic design of the supercritical fluid extraction (SFE) unit.

The experimental design chosen for this study was that of Box and Behnken (BBD). BBD was applied to determine optimum extraction pressure, temperature and particle size for supercritical CO<sub>2</sub> extraction of *S. mahagoni* seed. The pressure (A), temperature (B), and particle size (C) were independent variables studied to optimize the linoleic acid (Y) from *S. mahagoni* seed. The CO<sub>2</sub> flow rate was constant.

Box-Behnken design requires an experiment number (N) according to the following equation.

$$N = 2k(k-1) + cp$$

Where k is the factor number and cp is the replicate number of the central point. Three levels (low, medium, and high) denoted as -1, 0, and +1, respectively of variables chosen for the experiments are given in Table 1. Analysis was performed using commercial software Design-Expert® v.6.0.4.

**Table 1.** Levels of variables chosen.

Variables	Levels		
	High (+)	Middle (0)	Low (-)
A; Pressure (MPa)	30	25	20
B; Temperature (°C)	60	50	40
C; Particle size (mm)	0.75	0.50	0.25

The analysis of variance (ANOVA) was also used to evaluate the quality of the fitted model. The test of statistical difference was based on the total error criteria with a confidence level 95%.

Determination of active constituents from extracted compounds were examined using Gas Chromatography-Mass Spectrometry (GC-MS) as described by Kandhro, *et al.* [23]. with slight modification. In order to evaluate the quality of extracted compounds, all the sample were analyzed by using gas chromatography-mass spectrometry. The GC-MS analysis for fatty acid methyl ester (FAMES) was performed on Agilent 1909Is-433. A capillary column HP-5MS (5% phenyl

methylsiloxane) with dimension of 30  $\mu$ m x 0.25 mm i.d x 0.25  $\mu$ m film thickness (Agilent Technologies, Palo Alto, CA, USA) were used for separation of fatty acid methyl esters. The initial temperature 150°C was maintained for 2 min raised to 230°C at the rate of 4°C/min, and kept at 230°C for 5 min. The split ratio was 1:50, and helium were used carrier gas with the flow rate of 0.8 ml/min. The injector and detector temperature are 240 and 260°C, respectively. The mass spectrometer was operated in the electron impact mode at 70 eV in the scan range of 50-550 m/z.

### 3. Results and Discussion

Since various parameters potentially affect the extraction process, the optimization of the experimental conditions represents a critical step in the application of the SFE method. The experimental design was adopted on the basis of coded level from three variables (Table 1), resulting in seventeen simplified experimental sets (Table 2) with five replicates for the central point. The selected factors were extraction pressure (in MPa), temperature (in °C) and particle size (in mm) with the consideration that these factors are important in the extraction process.

**Table 2.** Experimental matrix and values of the observed response.

Run	A	B	C	Coded A variable	Coded B variable	Coded C variable	Observed Linoleic acid (peak area %)	Predicted of linoleic acid
1	20	40	0.50	-1	-1	0	25.61	27.15
2	30	40	0.50	+1	-1	0	19.92	21.40
3	20	60	0.50	-1	+1	0	23.74	22.26
4	30	60	0.50	+1	+1	0	33.58	32.04
5	20	50	0.25	-1	0	-1	27.30	26.00
6	30	50	0.25	+1	0	-1	31.53	30.29
7	20	50	0.75	-1	0	+1	31.10	32.35
8	30	50	0.75	+1	0	+1	30.78	32.09
9	25	40	0.25	0	-1	-1	26.71	26.47
10	25	60	0.25	0	+1	-1	24.03	26.82
11	25	40	0.75	0	-1	+1	30.81	28.02
12	25	60	0.75	0	+1	+1	33.18	33.42
13	25	50	0.50	0	0	0	30.80	33.58
14	25	50	0.50	0	0	0	26.88	33.58
15	25	50	0.50	0	0	0	37.58	33.58
16	25	50	0.50	0	0	0	37.15	33.58
17	25	50	0.50	0	0	0	35.47	33.58

The second order polynomial model used to express the total extraction linoleic acid (LA) of *S. mahagoni* as a function of independent variables (in terms of coded values) is shown below:

$$LA = 33.58 + 1.01 * A + 1.44 * B + 2.04 * C - 3.18 * A^2 - 4.68 * B^2 - 0.21 * C^2 + 3.88 * A * B - 1.14 * A * C + 1.26 * B * C$$

Assessment of extracts and linoleic acid from *S. mahagoni* seed at extreme carbon dioxide extraction was carried out at pressures (20, 25 and 30 MPa), temperature (40, 50 and 60°C) and particle size (0.25, 0.50 and 0.75 mm). The study proved that the optimum yield of *S. mahagoni* seed was linoleic acid content was 34.91% at 29.02 MPa pressure, temperature 67.88°C and particle size 0.75 mm with the equivalent value of this condition was 0.92 (desirability). The accuracy of the predicted value can be seen from the desirability value. Determination of desirability values serves to state the degree of optimum result of precision, which is closer to value 1, the higher the optimization value of precision [24]. The validation of the accuracy of this extraction condition was obtained from the results of the experimental extract of 20.07% and linoleic acid yield of 34.26%, this result shows agreement with the value predicted by Design Expert software



The effect of extraction pressure and temperature on linoleic acid yield at constant particle size, the effect of extraction pressure and particle size on linoleic acid yield at constant temperature and also the effect of extraction temperature and particle size on linoleic acid yield at constant pressure were illustrated in Figure 2, Figure 3 and Figure 4 respectively. As shown in Figure 2, linoleic acid increased with the increased in pressure from 20 MPa to 25 MPa and temperature 40°C to 50°C at constant particle size (0.5 mm). However, further increase in pressure from 25 MPa to 30 MPa and temperature from 50°C to 60°C resulted in decreasing of linoleic acid. Meanwhile, in Figure 3, it shows that at constant temperature, linoleic acid increased with increased pressure from 20 MPa to 30 MPa and particle size 0.25 mm to 0.75 mm. Furthermore, in Figure 4 showed linoleic acid increased with the increased in temperature from 40°C to 50°C and started to decrease when further increased from 50°C to 60°C at constant pressure (25 MPa). The study shows that the effect of SC-CO<sub>2</sub> parameters on the linoleic acid did not have the same traits as the effect of the SC-CO<sub>2</sub> parameter on the extracted oil.

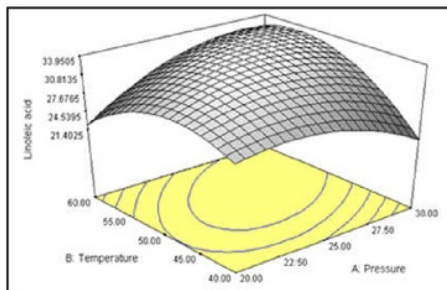

**Figure 2.** Surface plot of linoleic acid from *S mahagoni* as a function of pressure and temperature at constant particle size of 0.5 mm.

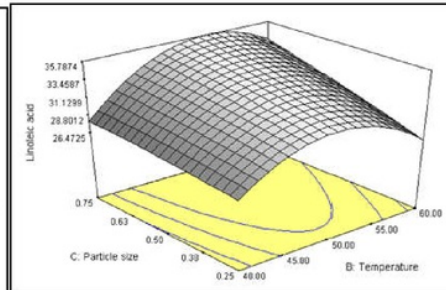

**Figure 3.** Surface plot of linoleic acid from *S mahagoni* as a function of pressure and particle size at constant temperature of 50°C

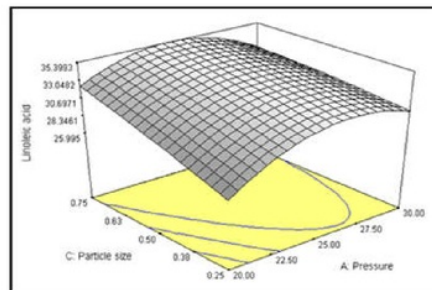
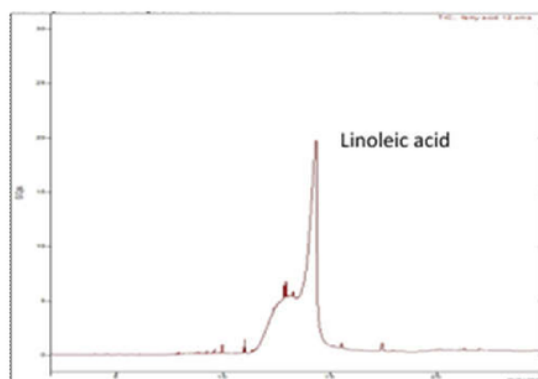

**Figure 4.** Surface plot of linoleic acid yield from *S mahagoni* as a function of temperature and particle size at constant pressure of 25 MPa

Effect of extraction condition on linoleic acid showed that linoleic acid of the extracts produced SC-CO<sub>2</sub> gave the different effect. But, Analysis of a variance of the data indicated that there was no statistically significant ( $p > 0.05$ ) difference between the other sample. Although there was greater variation within the sample, there was still no statistically significant effect of temperature and pressure on the extraction. The reason for the variation within the extract produced by SC-CO<sub>2</sub> extraction was due to the changes in the solubility of the linoleic acid with the changing extraction conditions.

The solubility of the oil in SC-CO<sub>2</sub> is mainly determined by the SC-CO<sub>2</sub> density and the volatility of the oil components. In general, SC-CO<sub>2</sub> density increases with pressure at constant temperature and decreases with temperature at constant pressure, where the density decrease becomes smaller at higher pressures. On the other hand, the volatility of oil components increases with temperature. These two opposing effects of temperature on density and volatility lead to the well-established crossover behavior of solubility isotherms. A temperature increase may also cause breakdown of cell structure and increase the diffusion rate of the oil in the particles, therefore accelerating the extraction process [25].

The fatty acid of *S. mahagoni* seed extracted SC-CO<sub>2</sub> were tested for GC-MS analysis (Table 2). There is one significant peak in the GC spectrums of the samples (Figure 5). Fatty acids have important roles in immune and inflammatory responses [26]. Monounsaturated and polyunsaturated fatty acids are present in plasma membranes, which are capable of stimulating cellular proliferation and angiogenesis, thus exert an important role in the process healing. The topical administration of linolenic (n-3) and linoleic (n-6) acids essential and oleic (n-9) acid nonessential fatty acids modulate the closure of surgically induced skin wounds [27]. The use of n-6 fatty acid may increase pro-inflammatory cytokines production in wound sites, stimulating the cutaneous wound healing process [28].



**Figure 5.** GC spectrums of fatty acid from *S. mahagoni* seed oils.

#### 4. Conclusion

The extraction of linoleic acid in supercritical carbon dioxide was measured as a function of pressure, temperature and particle size. Effect of extraction condition on linoleic acid of the extracts produced SC-CO<sub>2</sub> gave different effect. But, Analysis of variance of the data indicated that there was no statistically significant difference between the other sample. Although there was greater variation within the sample, there was still no statistically significant effect of temperature and pressure on the extraction. The optimum conditions for linoleic acid yield from *S. mahagoni* seed within the experimental range were found to be pressure of 29.02 MPa, a temperature of 67.88°C and particle size 0.75 mm, and the predicted linoleic acid was found to be 34.91%. Under these optimum conditions, the experimental values were in agreement with the predicted values.

#### Acknowledgments

We gratefully acknowledge the financial support by Ministry of Research and Higher Education Indonesia, and acknowledgement is also extended to Universitas Negeri Makassar and Universiti Teknologi Malaysia for the use of laboratory instruments.

## References

- [1] Chen Y Y, Wang X N, Fan C Q, Yin S and Yue J M 2007 *Tetrahedron Letters* **48** 7480-7484.
- [2] Guevara A P, Apilado A, Sakurai H, Kozuka M and Tokuda H 1996 *Philippine Journal of Science* **125** 271-278
- [3] Hartati, Liza M S, Ahmad R S, Azizi C Y and Azila A A 2014 *Jurnal Teknologi Science and Engineering* **67:4** 59-62
- [4] Bascall K, Chavez L, Diaz I, Espira S, Javillo J, Manzarilla H, Motalban J, Panganiban C., Rodriquez A, Sumpaico C, Talip B and Yap S 2005 *ActaMed. Philipp* **3** 127-1391997
- [5] Brunner G 2005 *Journal of food engineering* **67** 21-33
- [6] Sahena F, Zaidul L M, Jinap S, Karim A A, Abbas K A, Norulaini N A N and Omar A K M 2009 *Journal of Food Engineering* **95** 240-243
- [7] Reverchon E and De Marco I 2006 *The Journal of Supercritical Fluids* **38** 146-166
- [8] Reverchon E, Kazianus A and Marrone C 2000 *Chemical Engineering Science* **55** 2195-2201
- [9] Eller S C F J, Cermak and Taylor S I 2011 *Industrial Crops and products* **33** 554-557.
- [10] Ozkal S G 2009 *Journal of the American Oil Chemists Society* **86** 1129-1135
- [11] Westerman D, Santos R C D, Bosley J A, Roger J S and Al-Duri B 2006 *The Journal of Supercritical Fluids* **37** 38-52
- [12] Boutin O and Badens E 2009 *Journal of Food Engineering* **92** 396-402
- [13] Hartati, Liza M S, Yunus M A and Azila A A 2014 *JurnalTeknologi (Science and Engineering* **67** 1. 15-20
- [14] Yamini Y, Khajeh M, Ghasemi E, Mirza M and Javidnia K 2008 *Food Chemistry* **108** 341-346
- [15] Liu S, Yang F, Zhang C, Ji H, Hong P and Deng C 2009 *The Journal of Supercritical Fluids* **48** 9-14
- [16] Wei Z J, Liao A M, Zhang H X, Liu J and Jiang S T 2009 *Bioresource Technology* **100** 4214-4219
- [17] Shao P, Sun P and Ying Y 2008 *Food and Bioproducts Processing* **86** 227-231
- [18] Bhattacharjee P, Singhal R S and Tiwari S.R 2007 *Journal of Food Engineering*. 79: 892-898
- [19] Chang L, Jong T, Huang H, Nien Y, Chang C J 2006 *Separation and Purification Technolog* **47** 119-125
- [20] Machmudah S, Kawahito Y, Sasaki M and Goto M 2007 *J. Supercrit. Fluid* **41** 421-428
- [21] Wang H, Liu Y, Wei S and Yan Z 2012 *Food Chemistry* **132** 582-587
- [22] Kraujalis P and Venskutonis P R 2013 *The Journal of Supercritical Fluids* **73** 80-86
- [23] Kandhro A, Sherazi S T H, Mahesar S.A, Bhanger M I, Talpur M Y and Rauf A 2008 *Food Chemistry* **109** 207-211
- [24] Montgomery D C 2005 *Design and Analysis of Experiments, 6th ed.*, (John Wiley & Son, Inc ).
- [25] Martinez J L 2008 *Supercritical Fluid Extraction of Nutraceuticals and Bioactive Compounds*. (CRC Press Taylor & Francis Group LLC)
- [26] McClusker M M, Jane M M D and Grat-Kels M D 2010 *Clinics Dermatology* **28** 440-451.
- [27] Cardoso C R, Souza M A, Ferro E A., Favoreto J R and Pera J D S 2004 *Wound Repair Regen* **12** 235-243
- [28] Pereira L M, Hatanaka E and Martins E F 2008 *Cell BiochemFunct* **26** 197-204



# Response Surfaces of Linoleic Acid of Swietenia Mahagoni

## ORIGINALITY REPORT

9%

SIMILARITY INDEX

3%

INTERNET SOURCES

6%

PUBLICATIONS

0%

STUDENT PAPERS

## PRIMARY SOURCES

- 1** Danlami, Jibrin Mohammed, Muhammad Abbas Ahmad Zaini, Agus Arsad, and Mohd Azizi Che Yunus. "A parametric investigation of castor oil (*Ricinus communis* L) extraction using supercritical carbon dioxide via response surface optimization", *Journal of the Taiwan Institute of Chemical Engineers*, 2015. 3%  
Publication
- 2** Piotr Kuś, Igor Jerković, Martina Jakovljević, Stela Jokić. "Extraction of bioactive phenolics from black poplar (*Populus nigra* L.) buds by supercritical CO<sub>2</sub> and its optimization by response surface methodology", *Journal of Pharmaceutical and Biomedical Analysis*, 2018 3%  
Publication
- 3** [www.ajol.info](http://www.ajol.info) 2%  
Internet Source
- 4** Xiudong Wang, Chen Wang, Xianjun Zha, Yanan Mei, Jingxin Xia, Zhen Jiao. "Supercritical carbon dioxide extraction of  $\beta$ -" <1%

carotene and  $\alpha$ -tocopherol from pumpkin: a Box–Behnken design for extraction variables", *Analytical Methods*, 2017

Publication

---

5

Kaninika Paul, Paramita Bhattacharjee. "Mass transfer and hydrodynamic study of supercritical carbon dioxide extraction of 1,8-cineole from small cardamom seeds", *Chemical Engineering Communications*, 2018

Publication

---

<1%

---

Exclude quotes    On

Exclude matches    Off

Exclude bibliography    On